



REVE BACKWASH SYSTEM

SKU:476-32

Stunning and state-of-the-art, the Reve Collection is designed to add a touch of elegance and sophistication.

Made for as a Backwash System, the Reve shampoo unit with #3000 cultured-marble bowl features multiple storage options, sleek lines, clean simple box construction with no visible hardware, making this unit perfect for any salon.

Pictured with 1850L shampoo chair. Sold separately.

TECHNICAL INFORMATION

- Measures: 31 1/2"W x 15"D x 33 1/2"H
- Molded bottle well & tiered ledges
- Tip out soiled towel bin
- Plumbing access
- Storage cabinet
- Cultured marble #3000 bowl w/ fixtures/vacuum breaker
- 1850L Shampoo bowl ordered separately

SHIPPING INFORMATION

Item generally ships via Freight(Truck) service

- Weight: 159 lbs
- Dimensions: 48"L x 32"W x 42"H

WARRANTY

3 Years:

- Ball-Bearing Drawer Slides
- Cabinet hinges

1 Year:

- All remaining components, unless noted otherwise, are guaranteed for a period of one year from the date of purchase.



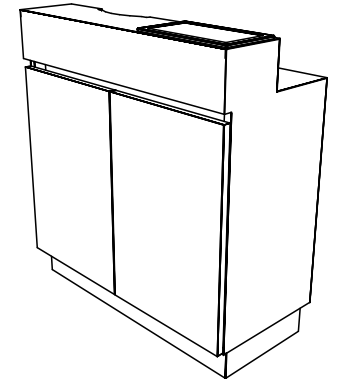
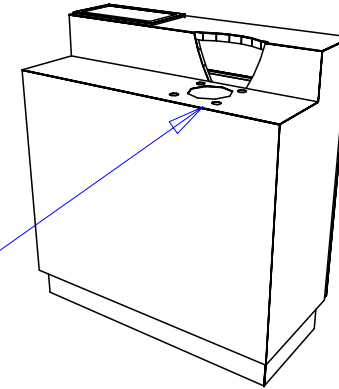

Black3000B Bowl

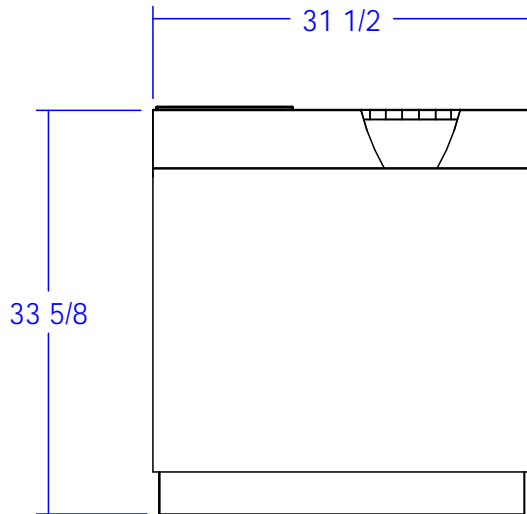
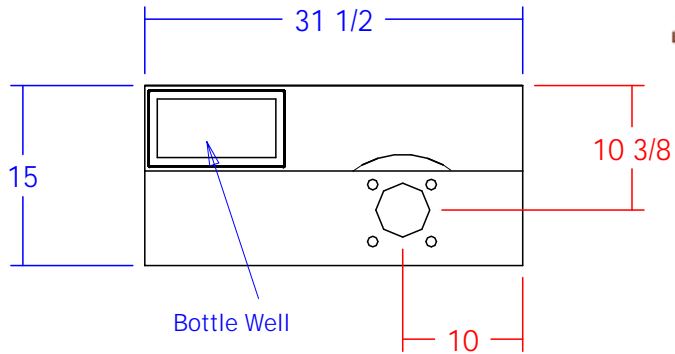

Front View

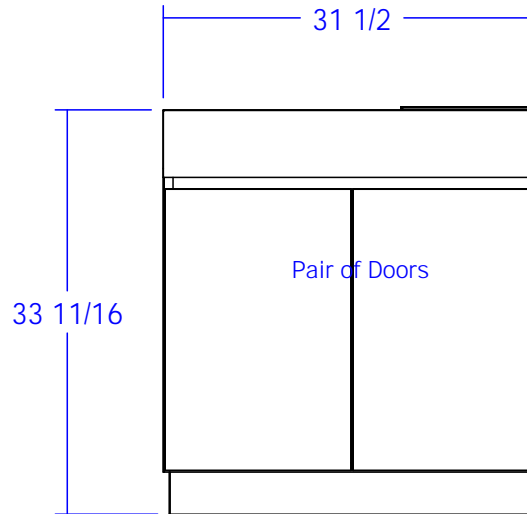

Back View

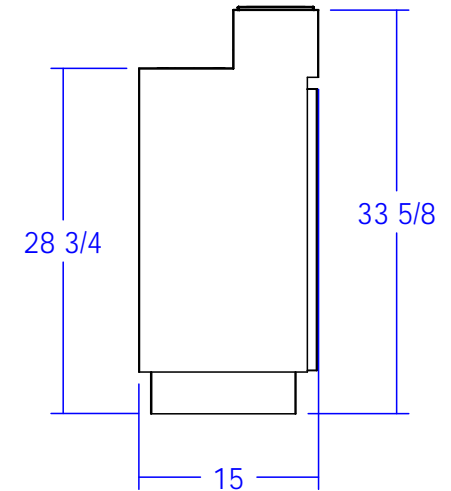

Quantity -

Finish Schedule -

- Face Color -
- Top Color -
- Toe Color -
- Reveal / Accent Color -
- Hardware -
- Interior -
- Other (Specify) -

This drawing is the property of Collins Manufacturing Company and is protected under copyright law.

 Collins Manufacturing 2000 Bowser Road Cookeville, TN 38506		
Title:		
Size: NTS	Drawing Number: Reve	Drawn By:
Date: 12/04/08	Sheet 1 of 1	