



CAPTIVA STYLING ISLAND

SKU:440-42



Make a statement with this stunning Captiva Styling Island.

The sturdy base and decorative molding along the top and ledge make a bold statement, perfect for tall rooms or large open spaces. Made for two back-to-back stylists, each with access to a built-in tool holder and shelving allow for storage on each side of the unit.

TECHNICAL INFORMATION

- Measures: 42"W x 18" D x 82"H
- Retail w/ adjustable glass shelves
- Quad-electric outlet
- 30" x 48" mirror
- Ledge
 - Blow dryer
 - Flat-iron
 - 2" Curling iron
- Includes base, ledge, soffit

SHIPPING INFORMATION

Item generally ships via Freight(Truck) service

- Weight: 430 lbs
- Dimensions: 2 skids

WARRANTY

3 Years:

- Ball-Bearing Drawer Slides
- Cabinet hinges

1 Year:

- All remaining components, unless noted otherwise, are guaranteed for a period of one year from the date of purchase.

Adjacent cabinets and components should be assembled by fastening through the interior panels with the screws or bolts provided. Tighten securely.

Mirrors are provided with mirror clips and wood screws. Attach one mirror clip at each corner approximately 2" in from the vertical edge.

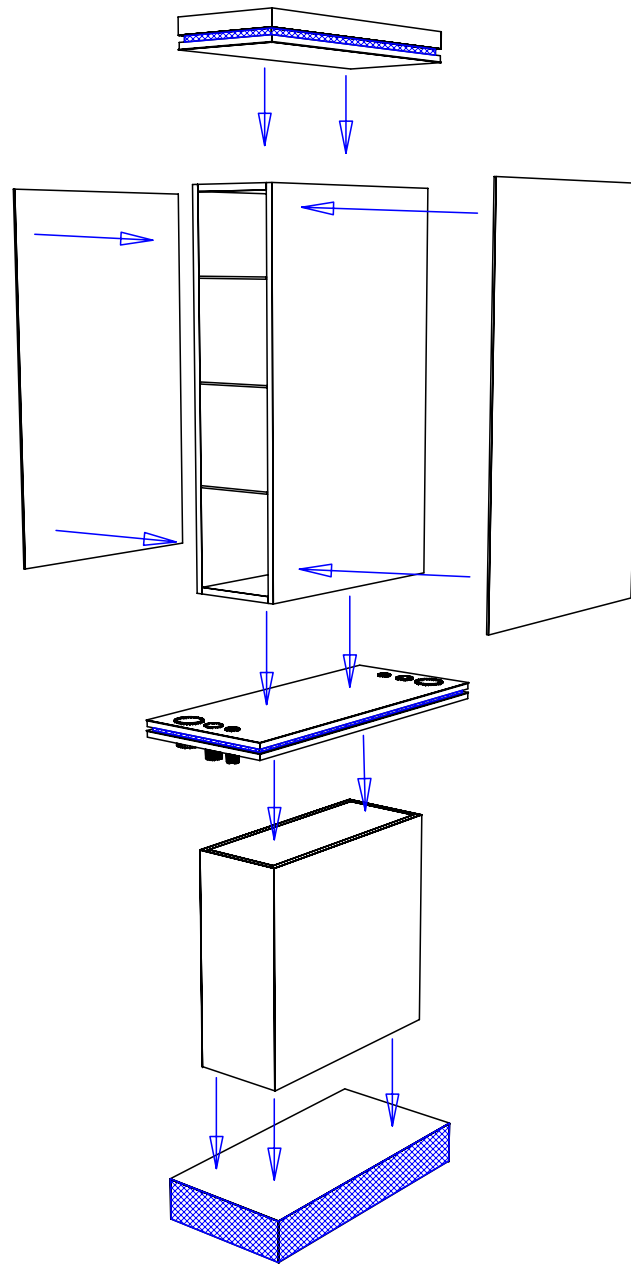

Finish Schedule -

Face Color -
 Top Color -
 Toe Color -
 Pulls -
 Interior -
 Other (Specify) -

General Notes:

1. All counter tops are to be made removable wherever possible.
2. Items must be broken into manageable sections For Shipping. Mark For Ease Of Reassembly.
3. Install Shipping Cleats Wherever Possible To Prevent Shipping Damage.
4. Purchased items Must Be Trial Fit Before Shipping.



Collins Manufacturing
 2000 Bowser Rd.
 Cookeville TN 38506

Title: 440-42 QSEp Captiva Styling Island

Size: # Drawn By:

Date: Sheet #: 7

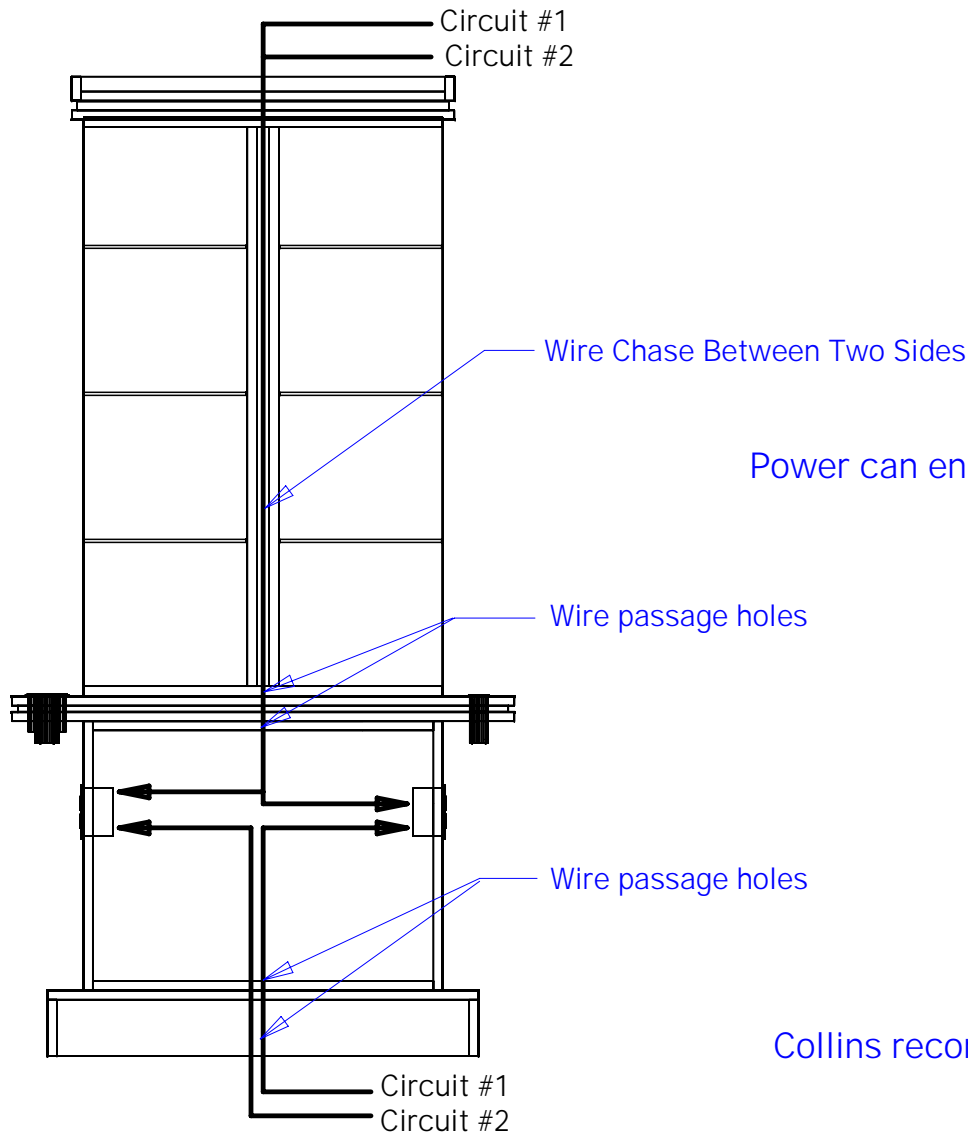

Power can enter the station from the floor or from the ceiling.

Collins recommends a 110 volt - 20 amp circuit per stylist.

Quantity -

Finish Schedule -

Face Color -
 Top Color -
 Toe Color - (Specify)
 Pulls -
 Interior -
 Other (Specify) -

General Notes:

1. All counter tops are to be made removable wherever possible.
2. Items must be broken into manageable sections For Shipping. Mark For Ease Of Reassembly.
3. Install Shipping Cleats Wherever Possible To Prevent Shipping Damage.
4. Purchased items Must Be Trial Fit Before Shipping.

collins Collins Manufacturing
 2000 Bowser Rd.
 Cookeville TN 38506

Title: 440-42 QSEp Captiva Styling Island

Size: #: Drawn By:

Date: 03/31/06 Sheet #: 8

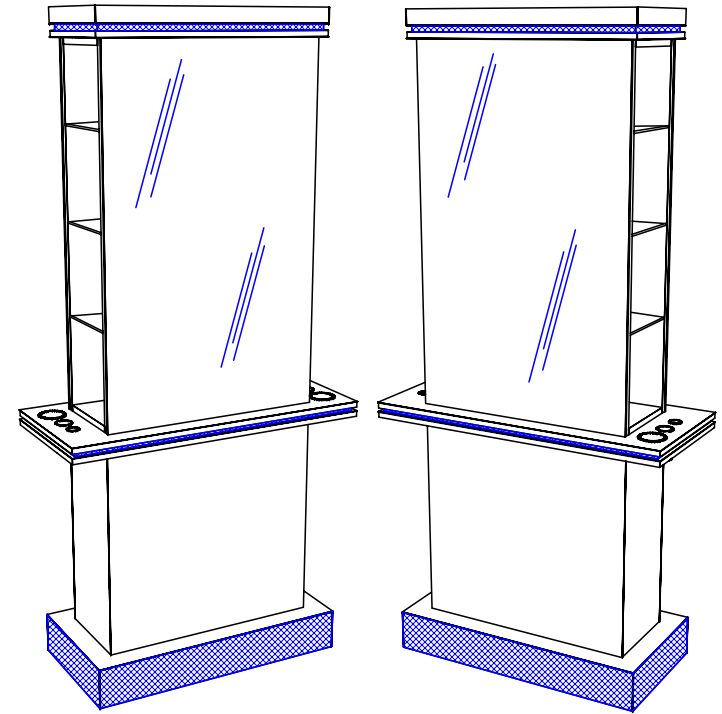
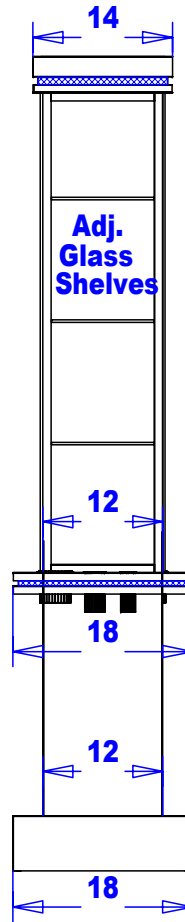
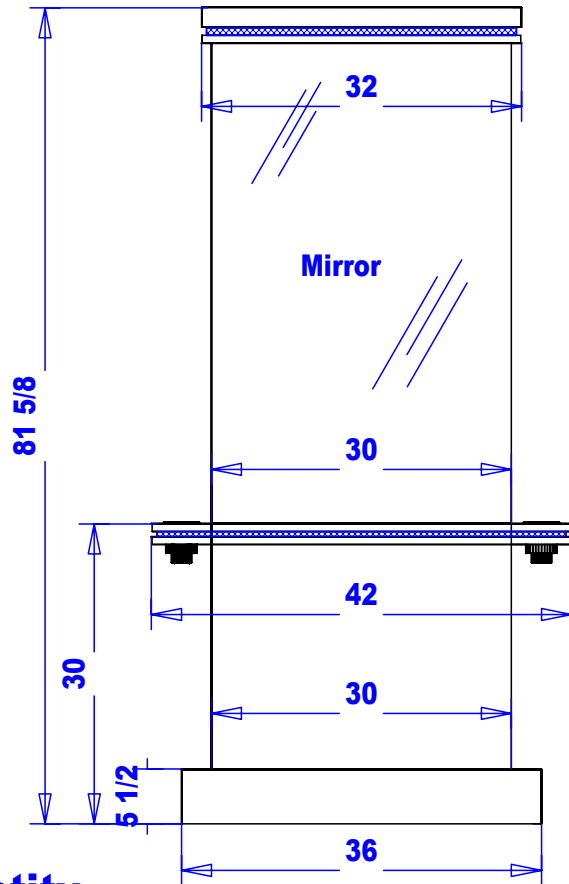
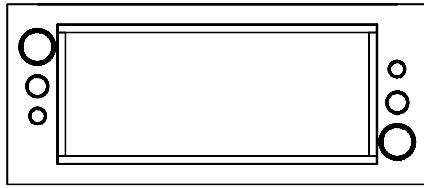

Quantity -

440-42 QSEp Captiva Styling Island

Finish Schedule -
Face Color -
Top Color -
Toe Color -
Pulls -
Interior -
Other (Specify) -

General Notes:
1. All counter tops are to be made removable wherever possible.
2. Items must be broken into manageable sections For Shipping. Mark For Ease Of Reassembly.
3. Install Shipping Cleats Wherever Possible To Prevent Shipping Damage.
4. Purchased items Must Be Trial Fit Before Shipping.

collins		Collins Manufacturing 2000 Bowser Rd. Cookeville TN 38506	
Title: 440-42 QSEp Captiva Styling Island			
Size:	#:	Drawn By:	
Date:	Sheet #:		6