



## REVE STYLING ISLAND WITH RETAIL

SKU:470-63

Stunning and state-of-the-art, the Reve Collection is designed to add a touch of elegance and sophistication.

Made for two back-to-back stylists, the Reve Island features retail shelving, sleek lines, clean simple style with no visible hardware, making this unit perfect for any salon



### TECHNICAL INFORMATION

---

- Measures: 63"W x 29"D x 81"H
- Full-extension drawer
- Cabinet w/ adjustable shelf
- Retail display w/ glass shelves
- 30" x 48" mirror
- Ledge
  - Blow dryer
  - Flat-iron
  - 2" Curling iron
- Quad electrical outlet for each stylist, wired on-site by electrician

### SHIPPING INFORMATION

---

Item generally ships via Freight(Truck) service

- Weight: 420 lbs
- Dimensions: 1 skid 2 cartons

### WARRANTY

---

#### 3 Years:

- Ball-Bearing Drawer Slides
- Cabinet hinges

#### 1 Year:

- All remaining components, unless noted otherwise, are guaranteed for a period of one year from the date of purchase.

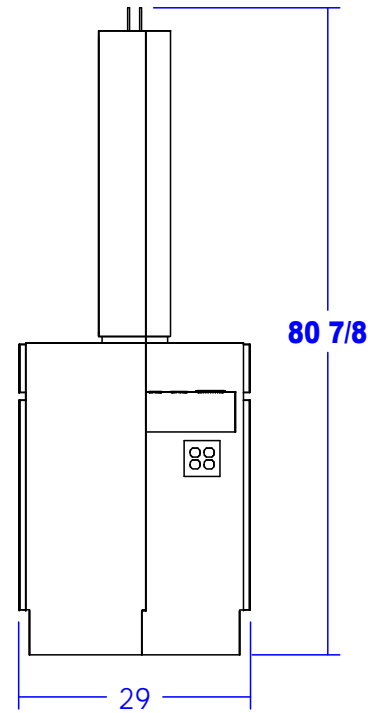
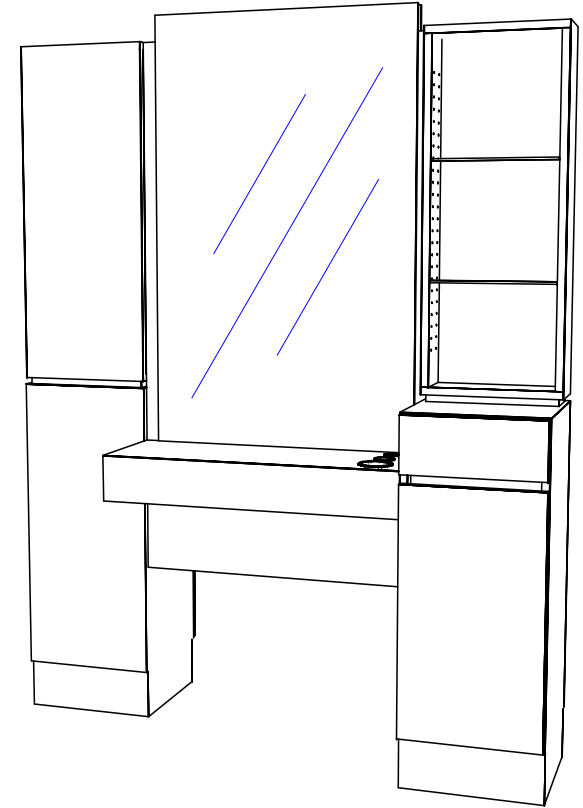
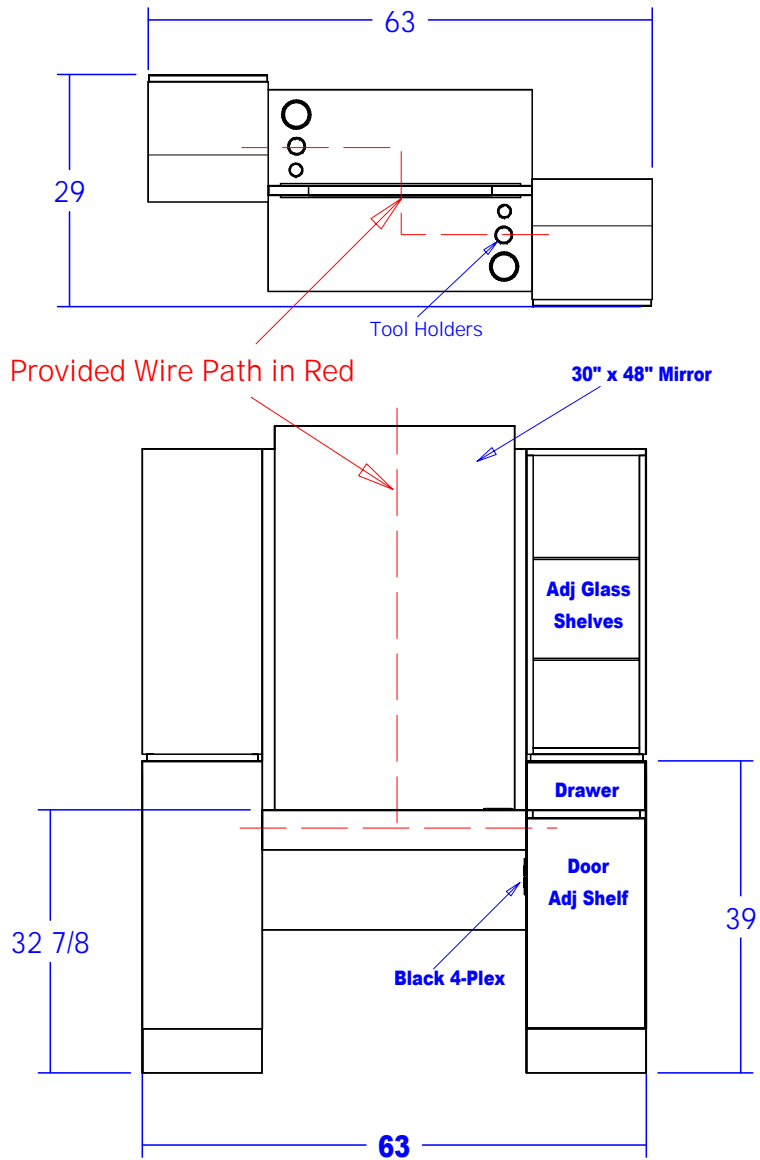

**Finish Schedule -**

Face Color -  
 Top Color -  
 Toe Color -  
 Reveal / Accent Color -  
 Hardware -  
 Interior -  
 Other (Specify) -

This drawing is the property of Collins Manufacturing Company and is protected under copyright law.

 Collins Manufacturing 2000 Bowser Road Cookeville, TN 38506		
Title: <b>470-63 Reve Retail Island</b>		
Size: NTS	Drawing Number: Reve	Drawn By:
Date: 12/09/08	Sheet 1 of 1	