



VANELLE FRAMED MIRROR

SKU:861-40

The Vanelle Framed Mirror is a unique contemporary piece with a dramatic design that is sure to be the focus of attention at your salon.

TECHNICAL INFORMATION

- Measures: 40"W x 8"D x 53"H
- Brushed stainless metallic laminate

SHIPPING INFORMATION

Item generally ships via Freight(Truck) service

- Weight: 230 lbs
- Dimensions: 60"L x 30"W x 54"H

WARRANTY

3 Years:

- Ball-Bearing Drawer Slides
- Cabinet hinges

1 Year:

- All remaining components, unless noted otherwise, are guaranteed for a period of one year from the date of purchase.



1/2" Luan French Cleat

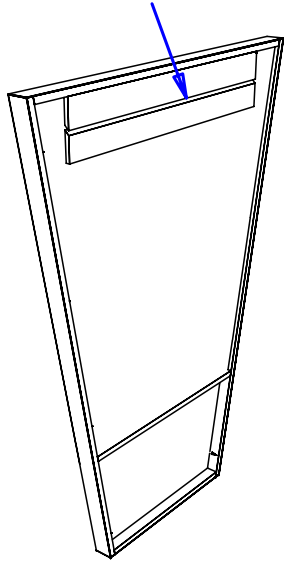

French cleat should be attached to the wall by screwing through the cleat into wall stud or blocking using the fasteners provided. The cleat should be level and at the indicated height.

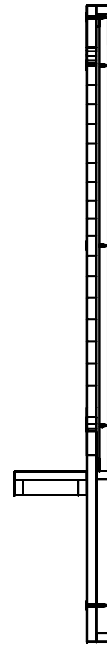
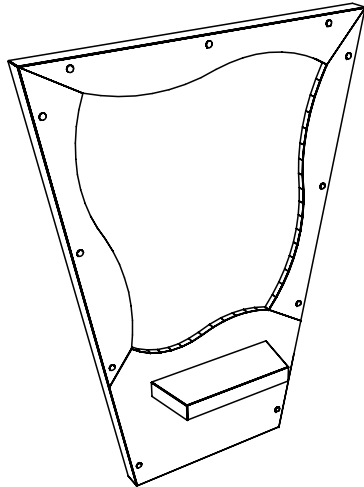

69 3/4" Above Floor (May Be Slightly Higher Or Lower To Meet Customer Preference.)

Finish Schedule

Face Color -
Top Color -
Toe Color -
Pulls -
Interior -
Other (Specify) -

Installation Notes:

1. All hardware needed for assembly is included.
2. Large items are preassembled at the factory to ensure proper alignment. Items are then disassembled into manageable sections for shipping purposes and ease of reassembly.
3. Shipping cleats need to be removed before installation. These cleats are installed to prevent damage.

collins

Collins Manufacturing
809 E 20th Street
Cookeville TN 38501

Title: **861-40 VANELLE MIRROR**

Size:

#:

Drawn By:

Mike

Date:

Sheet #: