



REVE SITTING DESK

SKU:2030-60

Stunning and state-of-the-art, the Reve Collection is designed to add a touch of elegance and sophistication.

Made for as a Sitting Reception Desk, the Reve Desk features multiple storage options, sleek lines, clean simple box construction with no visible hardware, making this unit perfect for any salon or spa.

TECHNICAL INFORMATION

- 60"W x 23"D x 43"H
- Measures: 60"W x 23"D x 43"H
- 2 Full extension drawers
- 2 Storage cabinets w/ shelves
- 30" Wide customer ledge
- 30" High work surface w/ pull out keyboard tray
- Computer ledge in chair well
- Wire grommets
- Sleek, no visible hardware

SHIPPING INFORMATION

Item generally ships via Freight(Truck) service

- Weight: 350 lbs
- Dimensions: 66"L x 32"W x 52"H

WARRANTY

3 Years:

- Ball-Bearing Drawer Slides
- Cabinet hinges

1 Year:

- All remaining components, unless noted otherwise, are guaranteed for a period of one year from the date of purchase.



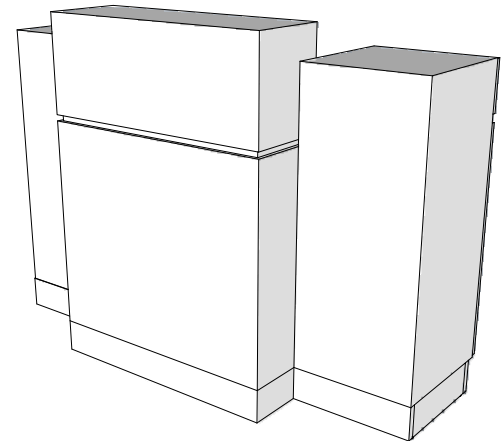
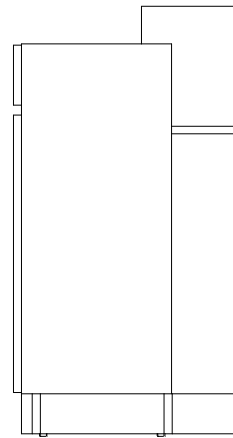
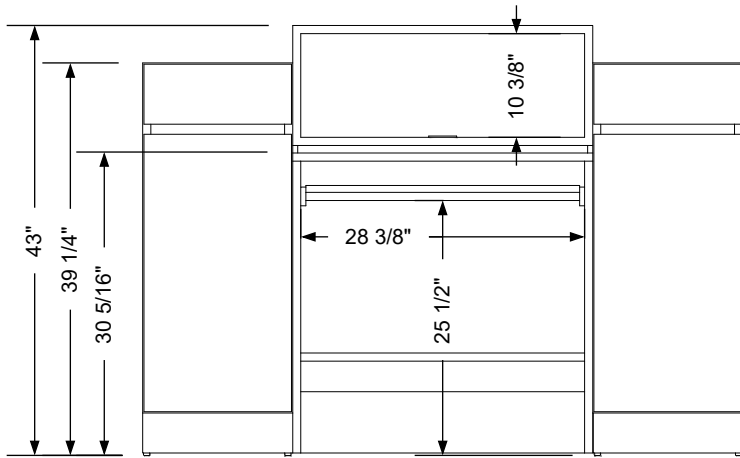
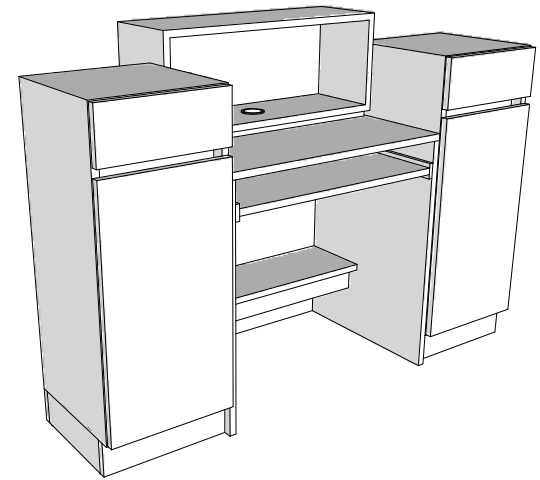
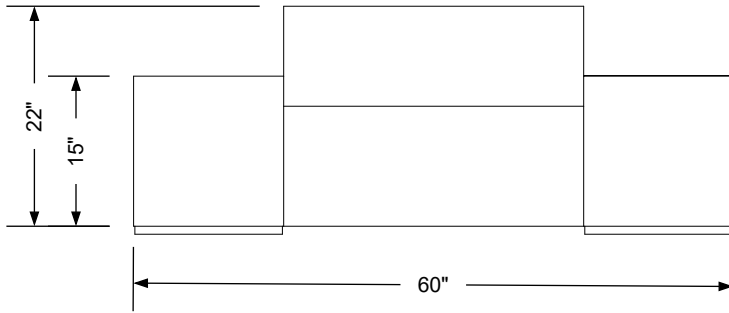

Additional Information

Assembly required - no
 Electrical required -yes
 Plumbing required - no
 Wall blocking required - no
 COM yardage/laminate usage - 110 sf
 4"h laminated plywood toe + 1/4"h glides
 Other (specify) - n/a
 Other (specify) - n/a

Specification Drawing

This **Specification Drawing** is intended for communicating the basic description, function, appearance, dimensions, features, and installation of an item as manufactured by Collins Manufacturing Company. Because this drawing does not contain project specific information such as quantities, finishes, or options, it is not an approval drawing and does not require a signature. This drawing remains the property of Collins Manufacturing Company and must not be used against the interests of Collins Manufacturing Company.

Product Information

		Collins Manufacturing 2000 Bowser Road Cookeville, TN 38506	
Name: Reve Sitting Desk			
Size: NTS	Part Number: 2030-60	Drawn By: Eng	
Prepared Date: 4/18/20	Revision Date: Date	Revision Number: Rev #	Sheet: 1 of 2

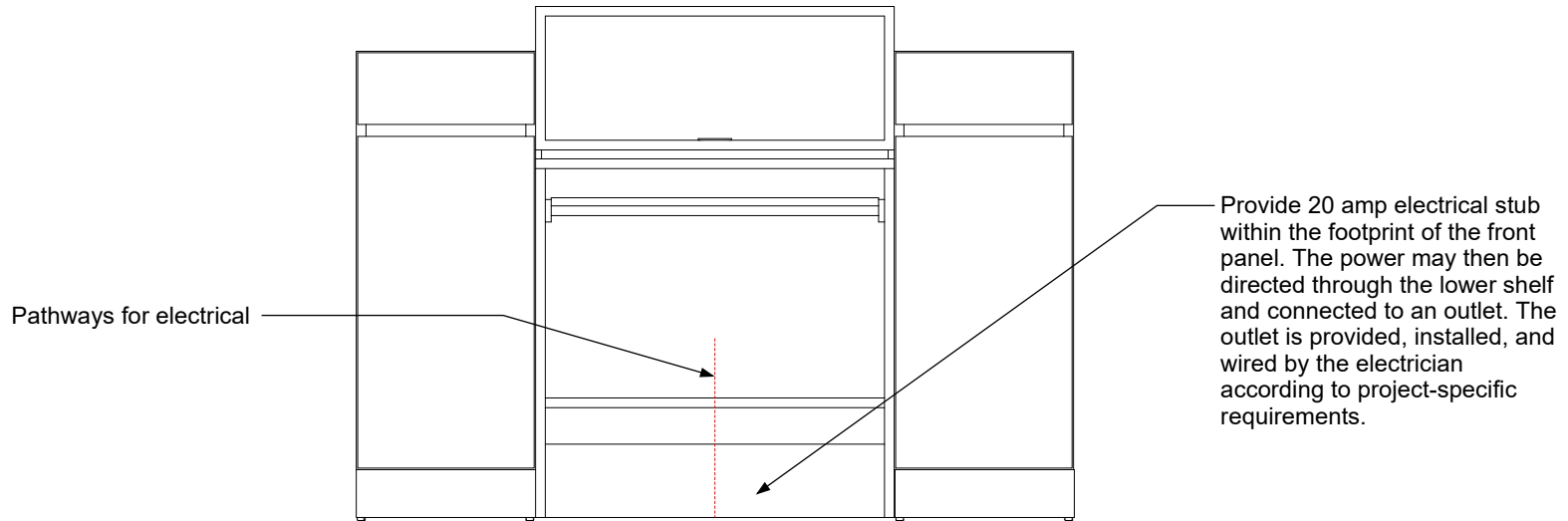
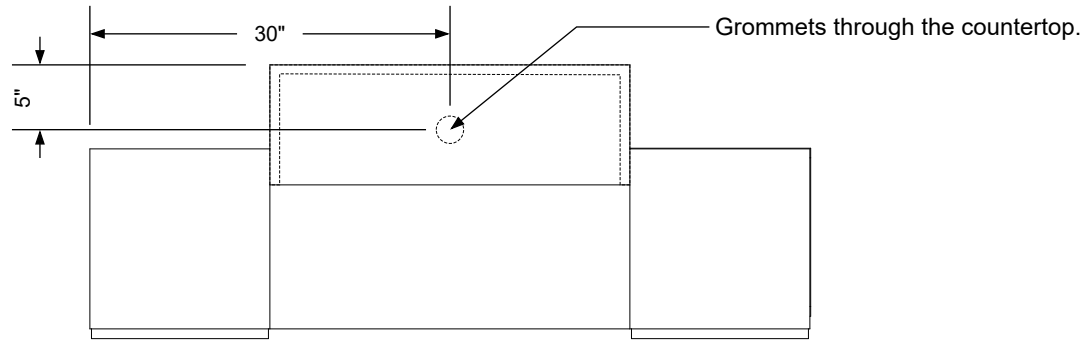

Electrical stub out detail

Additional Information

Assembly required - no
 Electrical required -yes
 Plumbing required - no
 Wall blocking required - no
 COM yardage/laminate usage - 110 sf
 4"h laminated plywood toe + 1/4"h glides
 Other (specify) - n/a
 Other (specify) - n/a

Specification Drawing

This **Specification Drawing** is intended for communicating the basic description, function, appearance, dimensions, features, and installation of an item as manufactured by Collins Manufacturing Company. Because this drawing does not contain project specific information such as quantities, finishes, or options, it is not an approval drawing and does not require a signature. This drawing remains the property of Collins Manufacturing Company and must not be used against the interests of Collins Manufacturing Company.

Product Information

		Collins Manufacturing 2000 Bowser Road Cookeville, TN 38506	
Name: Reve Sitting Desk			
Size: NTS	Part Number: 2030-60	Drawn By: Eng	
Prepared Date: 4/18/20	Revision Date: Date	Revision Number: Rev #	Sheet: 2 of 2