



MARCEL CART

SKU:2109-26



The Marcel Portable Styling Cart is beautifully designed to be a stylish and practical alternative to the traditional countertop. Constructed with heat resistant ceramic tile on the top, this station provides a resting place for your curling iron or thermal styling kits when not in use.

TECHNICAL INFORMATION

- 26"W x 16"D x 36"H
- Two drawers
- Storage cabinet w/ adjustable shelf and institutional hinges
- Oversized countertop w/ 12 x 12 heat resistant ceramic tile
- Tool panel
- 4 industrial casters
- Special MARCELtool holders (that can also be ordered separately and installed on any cabinet)

SHIPPING INFORMATION

Item generally ships via Freight(Truck) service

- Weight: 125 lbs
- Dimensions: 32"L x 30"W x 44"H

WARRANTY

3 Years:

- Ball-Bearing Drawer Slides
- Cabinet hinges

1 Year:

- All remaining components, unless noted otherwise, are guaranteed for a period of one year from the date of purchase.

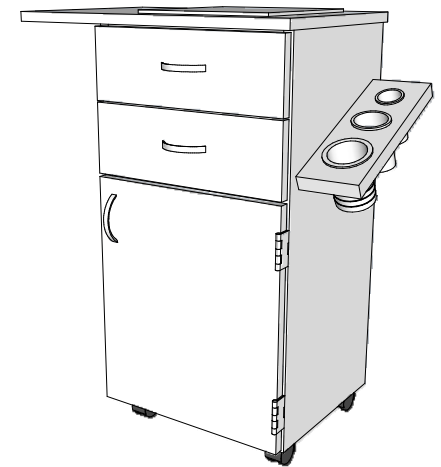
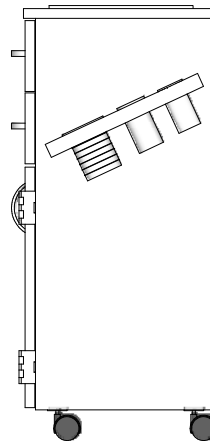
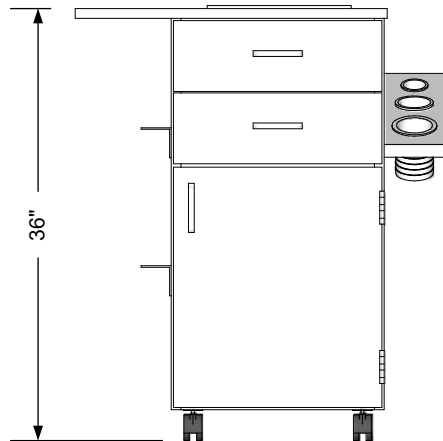
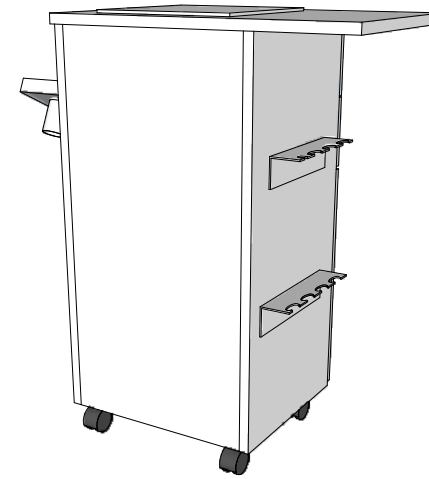
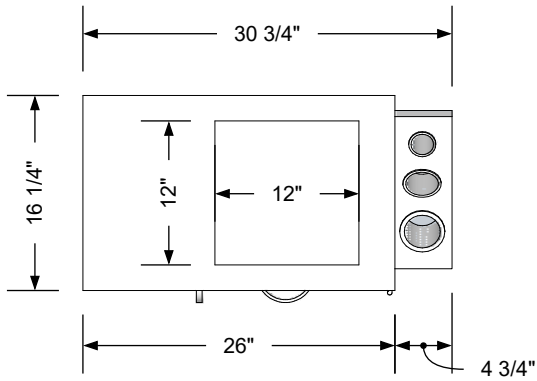

Additional Information

Assembly required - no
 Electrical required - yes
 Plumbing required - no
 Wall blocking required - no
 COM yardage/laminate usage - 26 sf
 2 1/2" h Twin wheel casters
 Other (specify) - n/a
 Other (specify) - n/a

Specification Drawing

This **Specification Drawing** is intended for communicating the basic description, function, appearance, dimensions, features, and installation of an item as manufactured by Collins Manufacturing Company. Because this drawing does not contain project specific information such as quantities, finishes, or options, it is not an approval drawing and does not require a signature. This drawing remains the property of Collins Manufacturing Company and must not be used against the interests of Collins Manufacturing Company.

Product Information

collins		Collins Manufacturing 2000 Bowser Road Cookeville, TN 38506	
Name: Marcel Cart			
Size: NTS	Part Number: 2109-26	Drawn By: Eng	
Prepared Date: 4/25/20	Revision Date: Date	Revision Number: Rev #	Sheet: 1 of 2

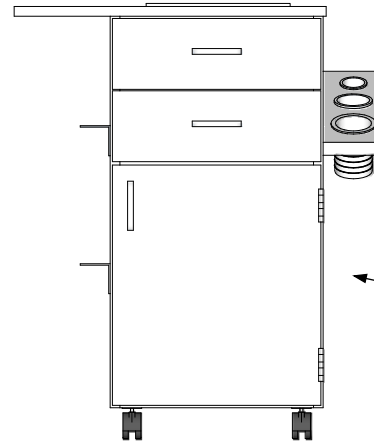
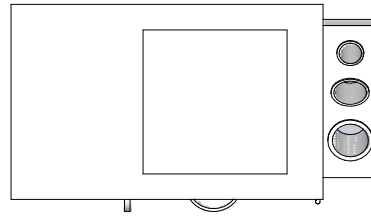

There is no power strip or outlet included with this unit. Electrician to provide, install, and wire a 20 amp outlet installed in the wall close to the tool panel.

Electrical stub out detail

Additional Information

Assembly required - no
 Electrical required - yes
 Plumbing required - no
 Wall blocking required - no
 COM yardage/laminate usage - 26 sf
 2 1/2" h Twin wheel casters
 Other (specify) - n/a
 Other (specify) - n/a

Specification Drawing

This **Specification Drawing** is intended for communicating the basic description, function, appearance, dimensions, features, and installation of an item as manufactured by Collins Manufacturing Company. Because this drawing does not contain project specific information such as quantities, finishes, or options, it is not an approval drawing and does not require a signature. This drawing remains the property of Collins Manufacturing Company and must not be used against the interests of Collins Manufacturing Company.

Product Information

		Collins Manufacturing 2000 Bowser Road Cookeville, TN 38506	
Name: Marcel Cart			
Size: NTS	Part Number: 2109-26	Drawn By: Eng	
Prepared Date: 4/25/20	Revision Date: Date	Revision Number: Rev #	Sheet: 2 of 2