



ALISON EASEL STATION

SKU:2105-30



With the Alison Easel styling station, you can show off your artistic style in an easy and organized way.

Featuring a sturdy stainless steel frame and countertop, this portable station comes with a built-in tool holder and drawer for supplies, as well as a bottom shelf for additional storage. Use it in your school, salon or anywhere else you want to express your unique style.

TECHNICAL INFORMATION

- 30.25"W x 21"D x 70.25"H
- stainless frame and counter top
- two four-plex outlets mounted beneath work surface
- tool holders conveniently built into right side of each stylist's workstation
- a center drawer on each side
- a laminated lower shelf that accommodates a student kit
- on-marring industrial casters

SHIPPING INFORMATION

Item generally ships via Freight(Truck) service

- Weight: 280 lbs
- Dimensions: 48"L x 32"W x 80"H

WARRANTY

3 Years:

- Ball-Bearing Drawer Slides
- Cabinet hinges

1 Year:

- All remaining components, unless noted otherwise, are guaranteed for a period of one year from the date of purchase.

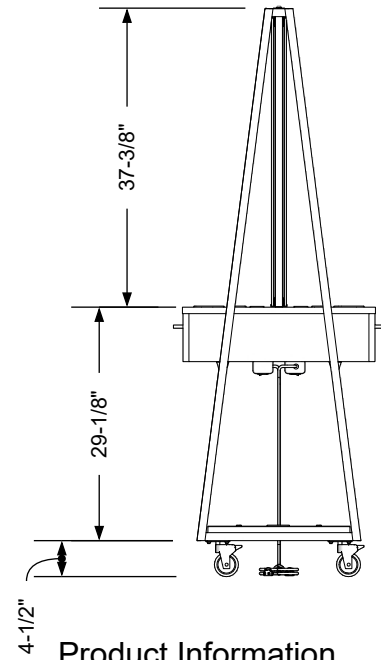
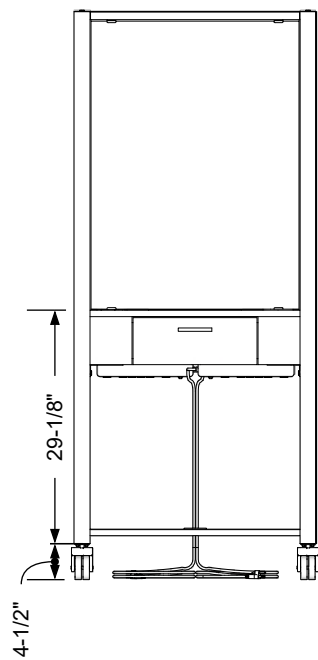
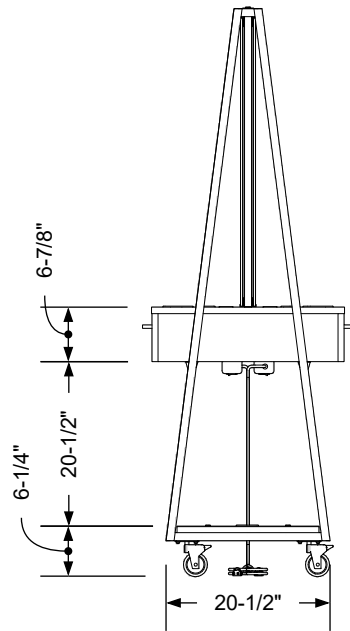
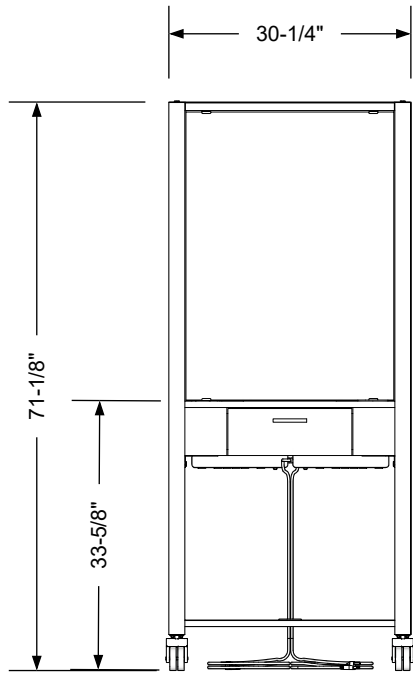
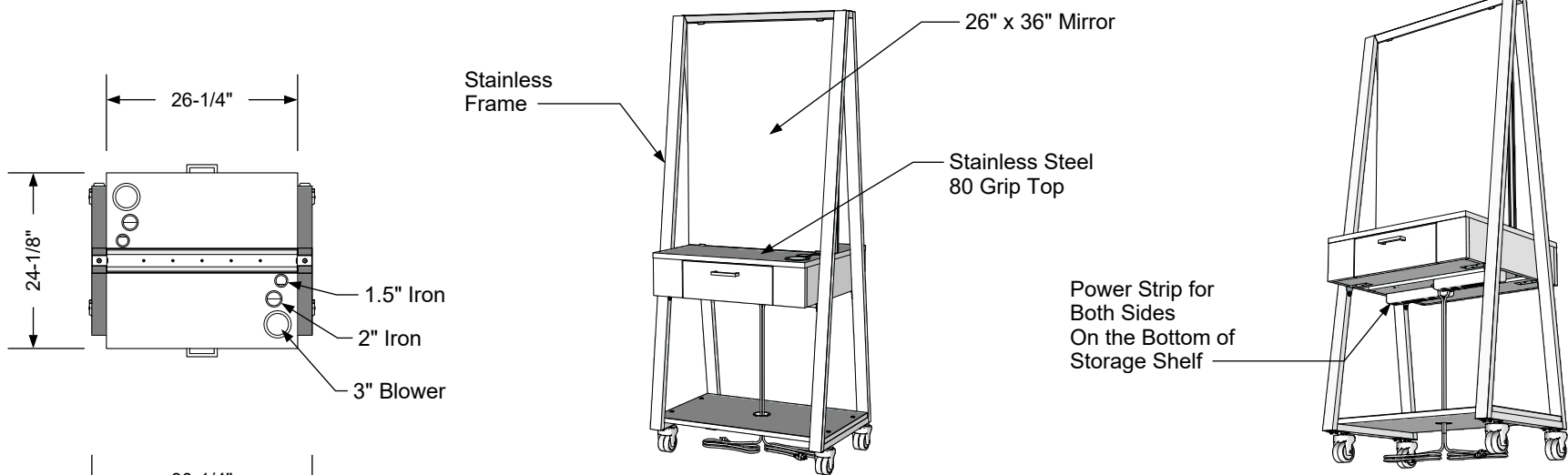

Additional Information

Assembly required - n/a
 Electrical required - yes
 Plumbing required - n/a
 Wall blocking required - n/a
 COM yardage/laminate usage - 18sf
 4 1/2" h Double Wheel Casters
 Other (specify) - n/a
 Other (specify) - n/a

Specification Drawing

This **Specification Drawing** is intended for communicating the basic description, function, appearance, dimensions, features, and installation of an item as manufactured by Collins Manufacturing Company. Because this drawing does not contain project specific information such as quantities, finishes, or options, it is not an approval drawing and does not require a signature. This drawing remains the property of Collins Manufacturing Company and must not be used against the interests of Collins Manufacturing Company.

Product Information

		Collins Manufacturing 2000 Bowser Road Cookeville, TN 38506	
Name: Alison Easel Station			
Size: NTS	Part Number: 2105-30	Drawn By: Eng	
Prepared Date: 6/12/20	Revision Date: 10/23/20	Revision Number: Rev 1	Sheet: 1 of 2

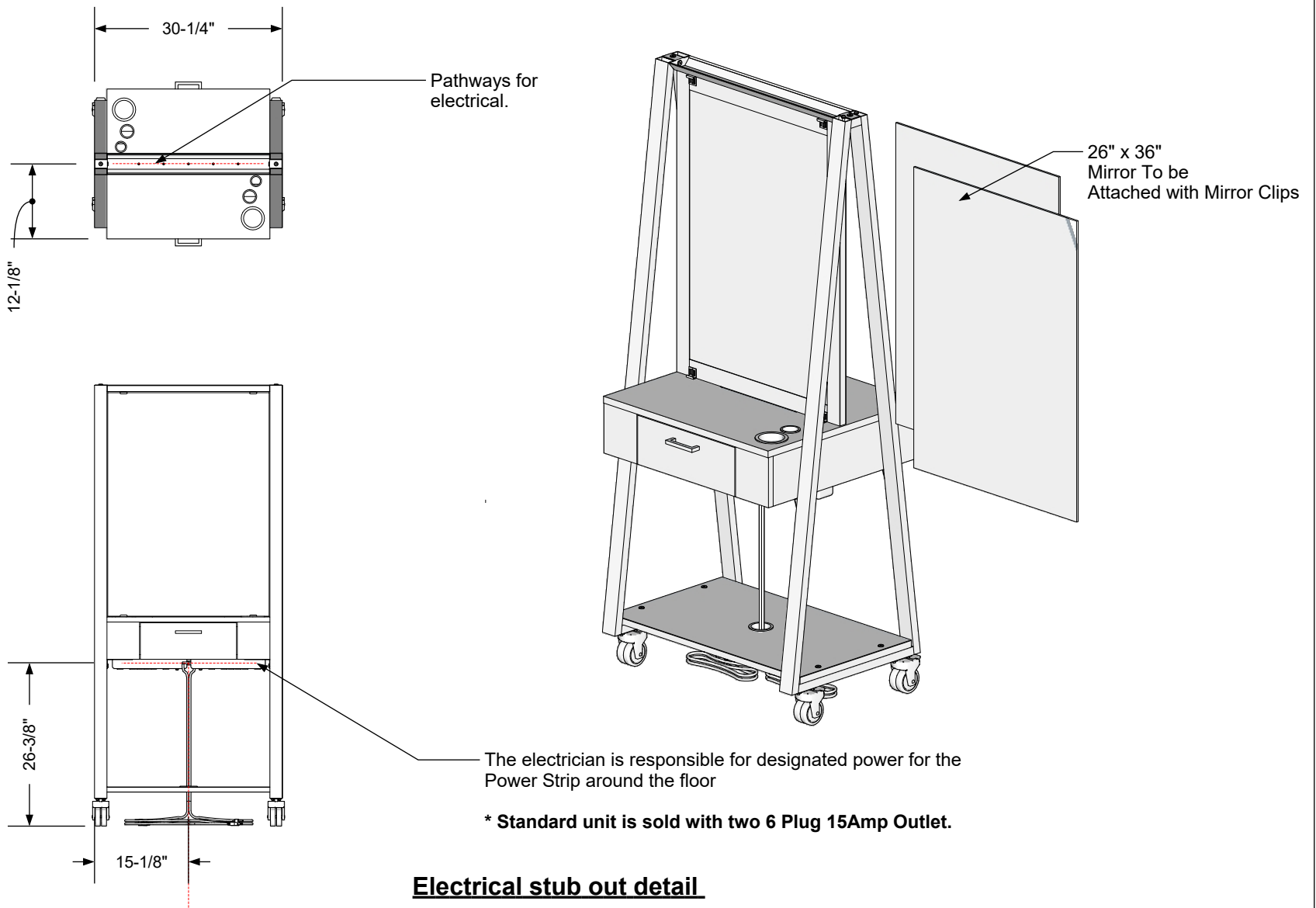

Additional Information

Assembly required - n/a
 Electrical required - yes
 Plumbing required - n/a
 Wall blocking required - n/a
 COM yardage/laminate usage - 18sf
 4 1/2" h Double Wheel Casters
 Other (specify) - n/a
 Other (specify) - n/a

Specification Drawing

This **Specification Drawing** is intended for communicating the basic description, function, appearance, dimensions, features, and installation of an item as manufactured by Collins Manufacturing Company. Because this drawing does not contain project specific information such as quantities, finishes, or options, it is not an approval drawing and does not require a signature. This drawing remains the property of Collins Manufacturing Company and must not be used against the interests of Collins Manufacturing Company.

Product Information

		Collins Manufacturing 2000 Bowser Road Cookeville, TN 38506	
Name: Alison Easel Station			
Size: NTS	Part Number: 2105-30	Drawn By: Eng	
Prepared Date: 6/12/20	Revision Date: 10/23/20	Revision Number: Rev 1	Sheet: 2 of 2