



VEECO AV-128 COMPLETE

SKU:2100-46



Our Veeco AV-128 styling station has an industrial-grade stainless steel construction, with a minimalist design that allows you to make the most of your space and showcase your style. The detachable supply cabinet provides ample storage for your styling tools, while the built-in tool holders and hooks help keep everything tidy and organized. Stainless top has 80 grit finish.

TECHNICAL INFORMATION

- 46"W x 34"D x 72"H
- All stainless steel construction
- Two sided workstation with framed mirrors
- Ledge w/ appliance holders
- Two-sided cabinet
- A total for four lockable storage compartments
- Heavy duty locking casters
- Two 20-amp quad outlets

SHIPPING INFORMATION

Item generally ships via Freight(Truck) service

- Weight: 345 lbs
- Dimensions: 32"W x 72"L x 48"H

WARRANTY

3 Years:

- Ball-Bearing Drawer Slides
- Cabinet hinges

1 Year:

- All remaining components, unless noted otherwise, are guaranteed for a period of one year from the date of purchase.

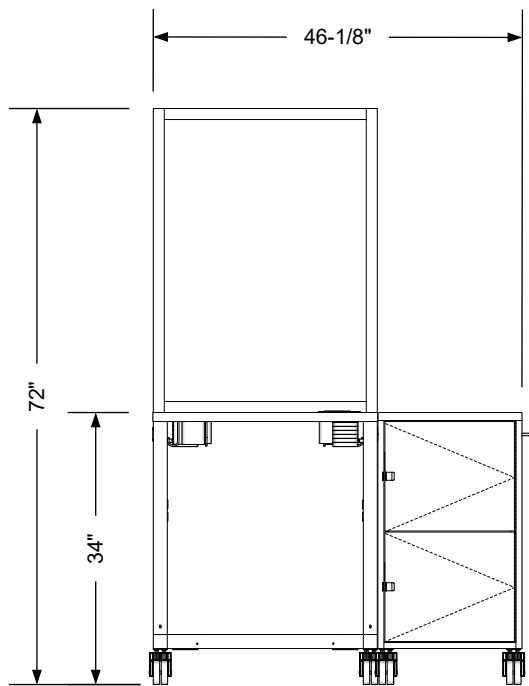
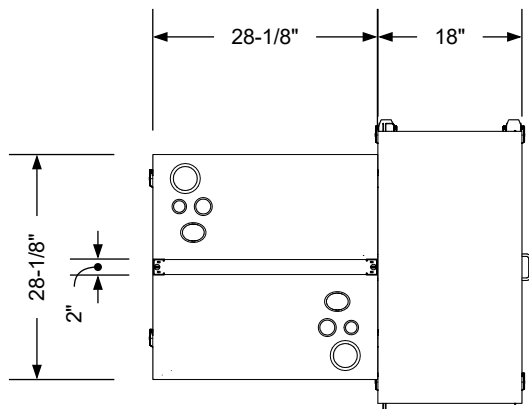

Designated Quad Outlet Per Leg

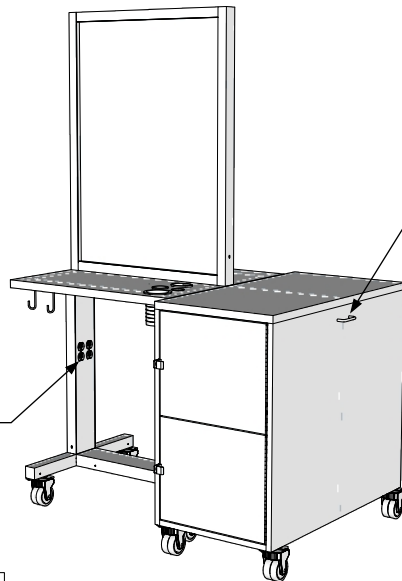

Push Latch For Releasing Docking Teeth

Wire Pull For Docking

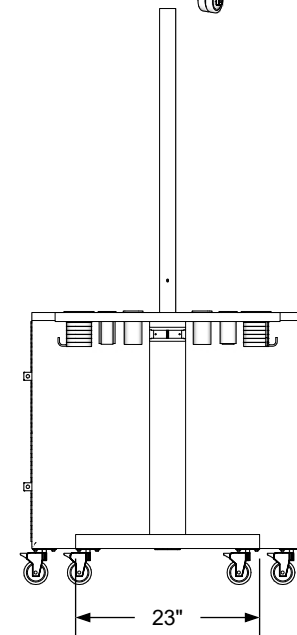
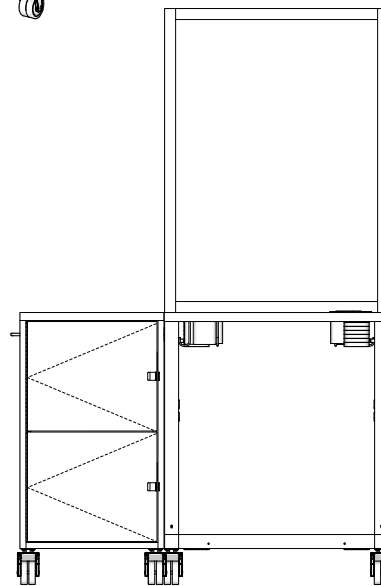
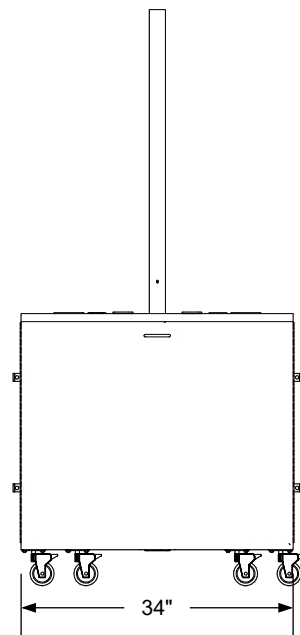
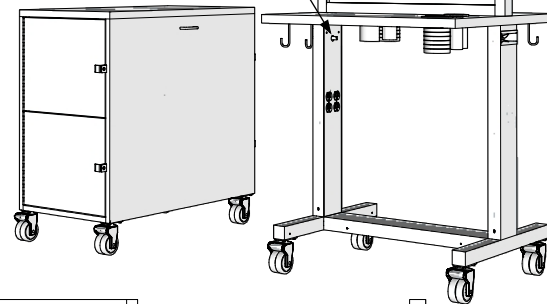

Additional Information

Assembly required - yes
 Electrical required - yes
 Plumbing required - n/a
 Wall blocking required - n/a
 COM yardage/laminate usage - 4 1/2" h Double Wheel Casters
 Other (specify) - n/a
 Other (specify) - n/a

Specification Drawing

This **Specification Drawing** is intended for communicating the basic description, function, appearance, dimensions, features, and installation of an item as manufactured by Collins Manufacturing Company. Because this drawing does not contain project specific information such as quantities, finishes, or options, it is not an approval drawing and does not require a signature. This drawing remains the property of Collins Manufacturing Company and must not be used against the interests of Collins Manufacturing Company.

Product Information

collins		Collins Manufacturing 2000 Bowser Road Cookeville, TN 38506	
Name: Veeco AV-128 Complete			
Size: NTS	Part Number: 2100-46	Drawn By: Eng	
Prepared Date: 5/19/20	Revision Date: 6/26/20	Revision Number: Rev 1	Sheet: 1 of 2

Approximate Length of Cord Needs to be requested for electrifying to the ceiling.

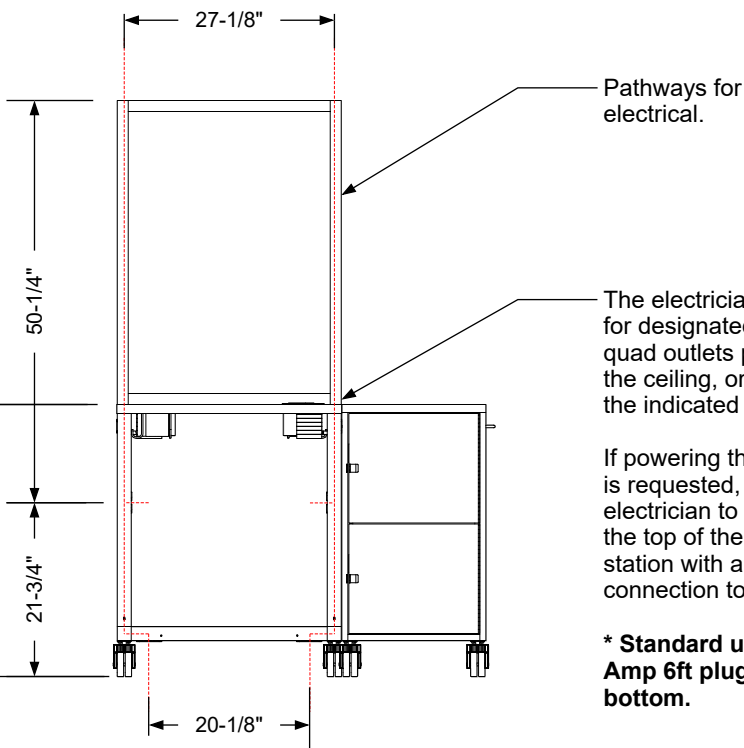
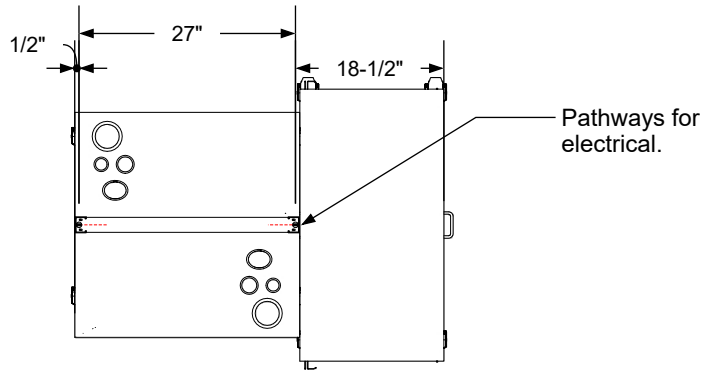

If powering the station from the ceiling is requested, Collins will require the electrician to wire specified length from the top of the 34" Work surface of the station with a Quick Disconnect connection to the ceiling outlets.

* Standard unit is sold with two 20 Amp 6ft plugable cord from the bottom.

Electrical stub out detail

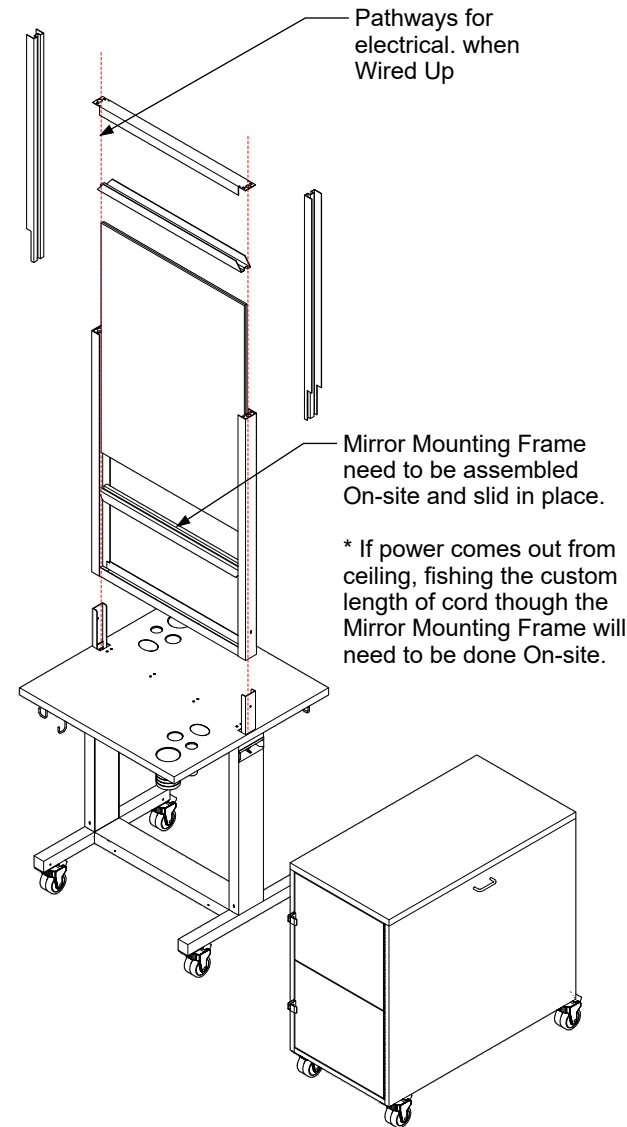

Additional Information

- Assembly required - yes
- Electrical required - yes
- Plumbing required - n/a
- Wall blocking required - n/a
- COM yardage/laminate usage - 4 1/2" h Double Wheel Casters
- Other (specify) - n/a
- Other (specify) - n/a

Specification Drawing

This **Specification Drawing** is intended for communicating the basic description, function, appearance, dimensions, features, and installation of an item as manufactured by Collins Manufacturing Company. Because this drawing does not contain project specific information such as quantities, finishes, or options, it is not an approval drawing and does not require a signature. This drawing remains the property of Collins Manufacturing Company and must not be used against the interests of Collins Manufacturing Company.

Product Information

		Collins Manufacturing 2000 Bowser Road Cookeville, TN 38506	
Name: Veeco AV-128 Complete			
Size: NTS	Part Number: 2100-46	Drawn By: Eng	
Prepared Date: 5/19/20	Revision Date: 6/26/20	Revision Number: Rev 1	Sheet: 2 of 2