



## VEECO WMS

SKU:2103-36



The Veeco WMS wall mounted styling station is constructed with a modern, sleek and functional design. The stainless steel laminate finish on the mirror frame allows it to have a clean and classic look that would go well with any decor. Stainless top has 80 grit finish. This styling station has built in tool holders and tool hooks to keep your students organized.

### TECHNICAL INFORMATION

---

- 28"W x 14"D x 39.25"H
- Stainless steel worksurface
- Laminated wall mounted framed mirror
- Stainless steel ledge w/ appliance holders

### SHIPPING INFORMATION

---

Item generally ships via Freight(Truck) service

- Weight: 125 lbs
- Dimensions: 48"L x 32"W x 48"H

### WARRANTY

---

#### 3 Years:

- Ball-Bearing Drawer Slides
- Cabinet hinges

#### 1 Year:

- All remaining components, unless noted otherwise, are guaranteed for a period of one year from the date of purchase.

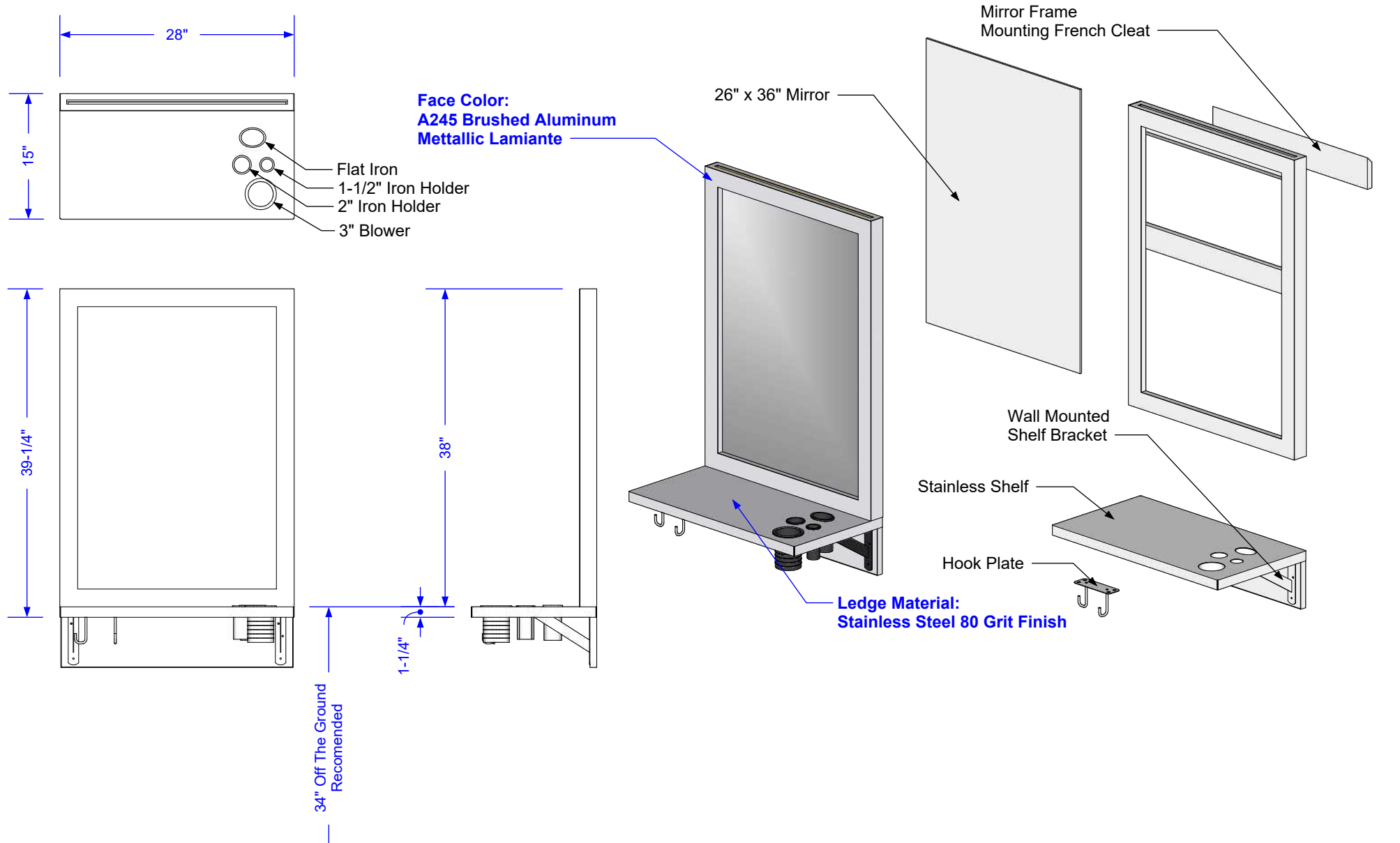

**Additional Information**

Assembly required - yes  
 Electrical required - n/a  
 Plumbing required - n/a  
 Wall blocking required - yes  
 COM yardage/laminate usage -  
 French Cleated Frame + Stainless Shelf  
 Other (specify) - n/a  
 Other (specify) - n/a

**Specification Drawing**

This **Specification Drawing** is intended for communicating the basic description, function, appearance, dimensions, features, and installation of an item as manufactured by Collins Manufacturing Company. Because this drawing does not contain project specific information such as quantities, finishes, or options, it is not an approval drawing and does not require a signature. This drawing remains the property of Collins Manufacturing Company and must not be used against the interests of Collins Manufacturing Company.

**Product Information**

<b>collins</b>		Collins Manufacturing 2000 Bowser Road Cookeville, TN 38506	
Name: Veeco WMS			
Size: NTS	Part Number: 2103-36	Drawn By: Eng	
Prepared Date: 1/5/22	Revision Date:	Revision Number: Rev 3	Sheet: 1 of 2

### Wall blocking detail - Front

Anchoring Bracket and Cleats  
to vertical wall studs is a second option for Installation.

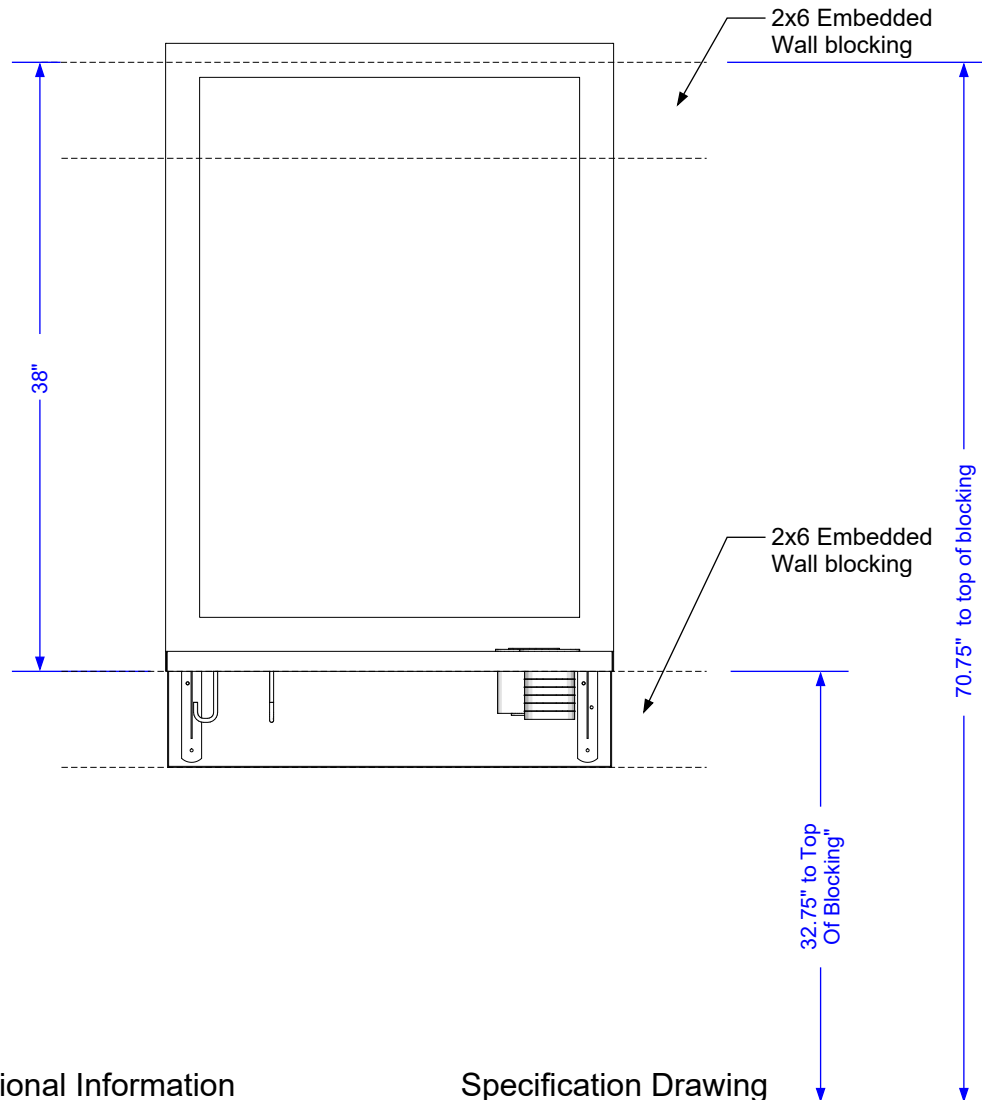

### Bracket Mounting detail - Side

Anchoring Bracket and Cleats  
to vertical wall studs is a second option for Installation.

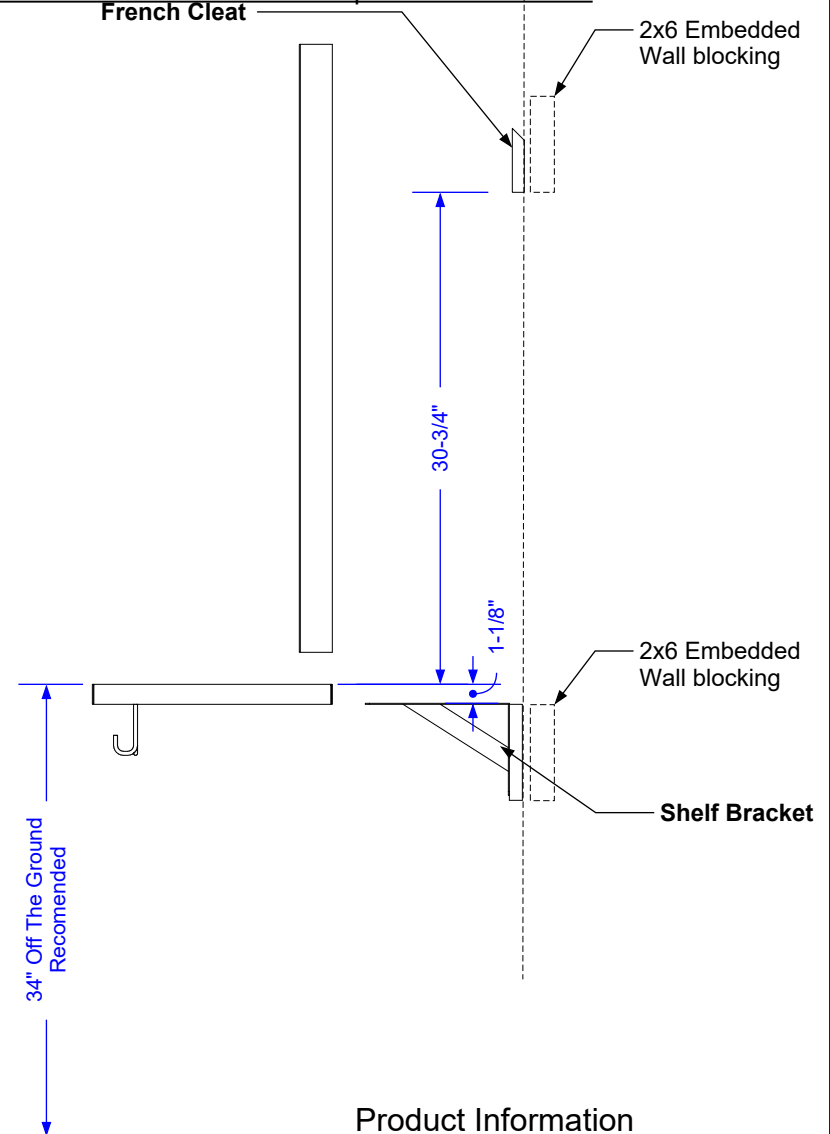

#### Additional Information

Assembly required - yes  
 Electrical required - n/a  
 Plumbing required - n/a  
 Wall blocking required - yes  
 COM yardage/laminate usage -  
 French Cleated Frame + Stainless Shelf  
 Other (specify) - n/a  
 Other (specify) - n/a

#### Specification Drawing

This **Specification Drawing** is intended for communicating the basic description, function, appearance, dimensions, features, and installation of an item as manufactured by Collins Manufacturing Company. Because this drawing does not contain project specific information such as quantities, finishes, or options, it is not an approval drawing and does not require a signature. This drawing remains the property of Collins Manufacturing Company and must not be used against the interests of Collins Manufacturing Company.

#### Product Information

<b>collins</b>		Collins Manufacturing 2000 Bowser Road Cookeville, TN 38506	
Name: Veeco WMS			
Size: NTS	Part Number: 2103-36	Drawn By: Eng	
Prepared Date: 1/5/22	Revision Date:	Revision Number: Rev 3	Sheet: 2 of 2