



## FCC ISLAND

SKU:2127-38



Our FCC Styling Island is built to help your students prep for success. This stylish station features two back-to-back stylist stations and plenty of storage options including drawers, shelving and a convenient ledge for essentials. It also has a built in tool holder on each side to keep your students organized.

### TECHNICAL INFORMATION

---

- 38"W x 38.5"D x 90"H
- Tool holders
- Drawer
- Work shelf
- Fourplex outlet
- Storage for mannequin heads for each student

### SHIPPING INFORMATION

---

Item generally ships via Freight(Truck) service

- Weight: 680 lbs
- Dimensions: 2 pallets

### WARRANTY

---

#### 3 Years:

- Ball-Bearing Drawer Slides
- Cabinet hinges

#### 1 Year:

- All remaining components, unless noted otherwise, are guaranteed for a period of one year from the date of purchase.

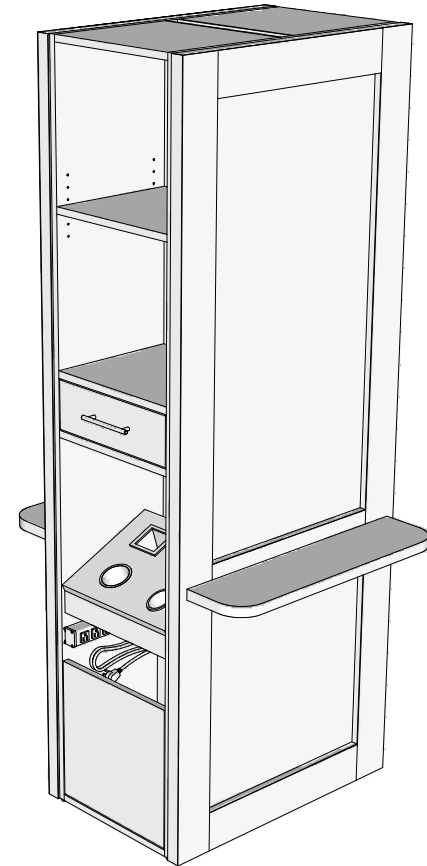
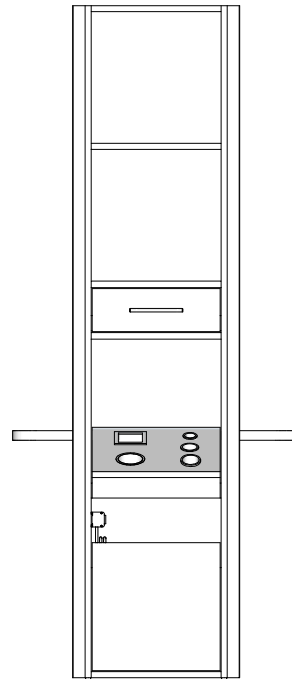
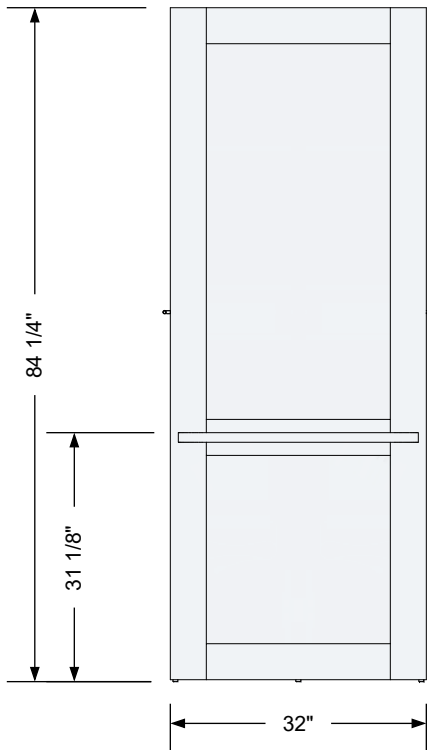
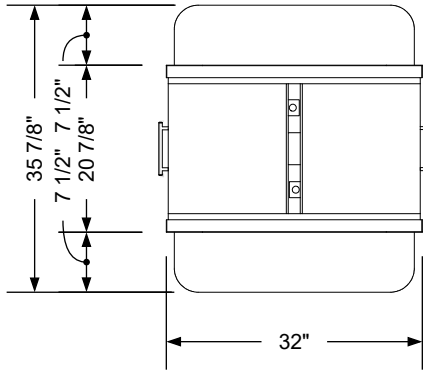

**Additional Information**

Assembly required - yes  
 Electrical required - yes  
 Plumbing required - no  
 Wall blocking required - no  
 COM yardage/laminate usage - 182 sf  
 No toe kick base + 1/4" h glides  
 Other (specify) - n/a  
 Other (specify) - n/a

**Specification Drawing**

This **Specification Drawing** is intended for communicating the basic description, function, appearance, dimensions, features, and installation of an item as manufactured by Collins Manufacturing Company. Because this drawing does not contain project specific information such as quantities, finishes, or options, it is not an approval drawing and does not require a signature. This drawing remains the property of Collins Manufacturing Company and must not be used against the interests of Collins Manufacturing Company.

**Product Information**

		Collins Manufacturing 2000 Bowser Road Cookeville, TN 38506	
Name: FCC Island			
Size: NTS	Part Number: 2127-38	Drawn By: Eng	
Prepared Date: 5/6/20	Revision Date: 4/21/22	Revision Number: Rev #1	Sheet: 1 of 1

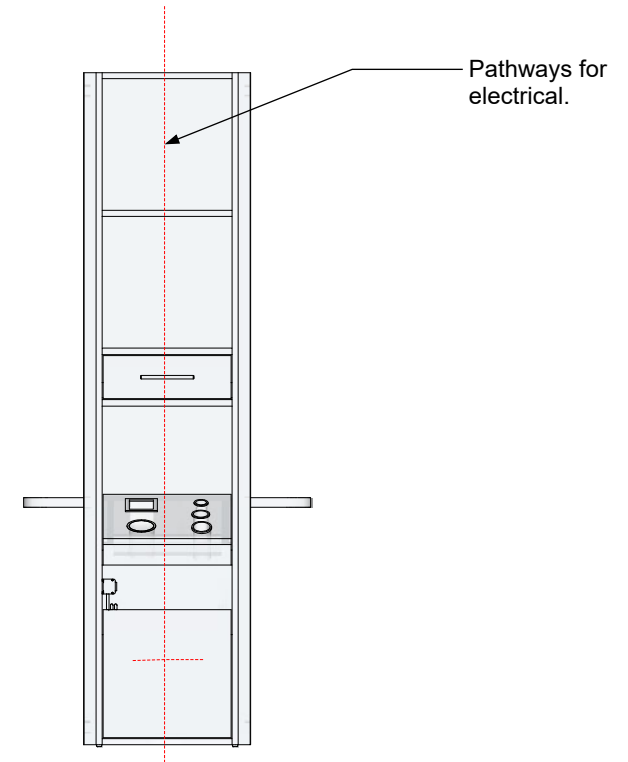
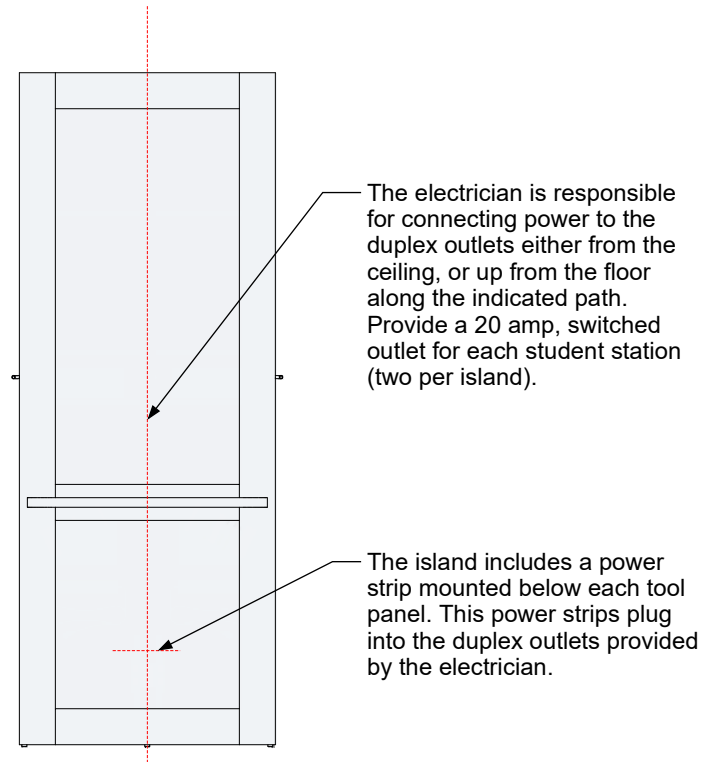
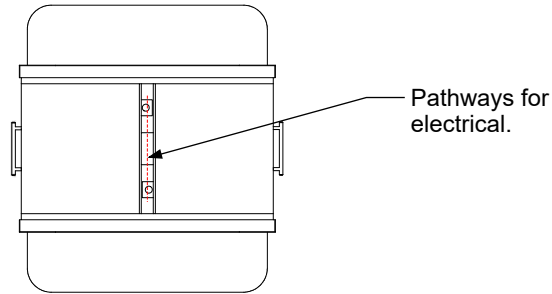

**Electrical stub out detail**

**Additional Information**

Assembly required - yes  
 Electrical required - yes  
 Plumbing required - no  
 Wall blocking required - no  
 COM yardage/laminate usage - 182 sf  
 No toe kick base + 1/4" h glides  
 Other (specify) - n/a  
 Other (specify) - n/a

**Specification Drawing**

This **Specification Drawing** is intended for communicating the basic description, function, appearance, dimensions, features, and installation of an item as manufactured by Collins Manufacturing Company. Because this drawing does not contain project specific information such as quantities, finishes, or options, it is not an approval drawing and does not require a signature. This drawing remains the property of Collins Manufacturing Company and must not be used against the interests of Collins Manufacturing Company.

**Product Information**

		Collins Manufacturing 2000 Bowser Road Cookeville, TN 38506	
Name: FCC Island			
Size: NTS	Part Number: 2127-38	Drawn By: Eng	
Prepared Date: 5/6/20	Revision Date: 4/21/22	Revision Number: Rev #1	Sheet: 2 of 2