



EMPEROR ISLAND

SKU:2125-34

Designed by and built for Empire Beauty Schools is an Island station made for two students.

TECHNICAL INFORMATION

- 34"W x 30.5"D x 72"H
- Stainless steel framed mirror
- Work surface with tool holders for each student
- Side mounted quad outlet per student

SHIPPING INFORMATION

Item generally ships via Freight(Truck) service

- Weight: 325 lbs
- Dimensions: 48"L x 32"W x 48"H

WARRANTY

3 Years:

- Ball-Bearing Drawer Slides
- Cabinet hinges

1 Year:

- All remaining components, unless noted otherwise, are guaranteed for a period of one year from the date of purchase.



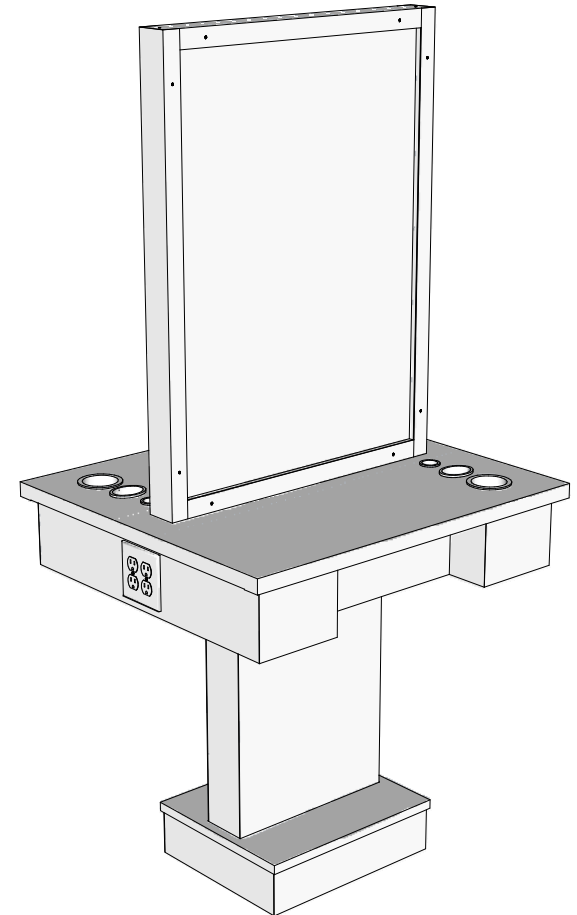
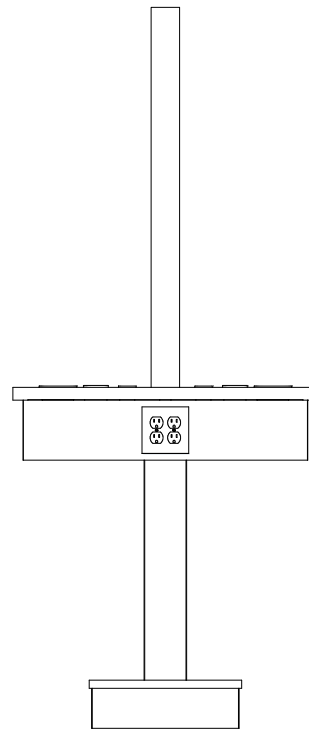
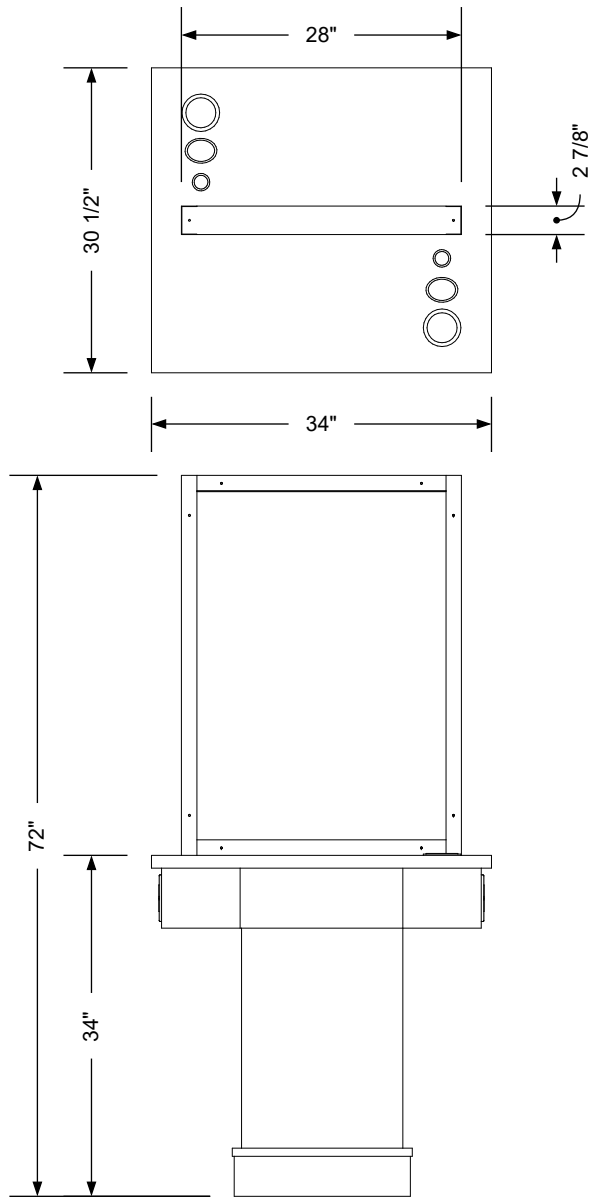

Additional Information

Assembly required - yes
 Electrical required - yes
 Plumbing required - no
 Wall blocking required - no
 COM yardage/laminate usage - 34
 4" h laminated plywood toe
 Other (specify) - n/a
 Other (specify) - n/a

Specification Drawing

This **Specification Drawing** is intended for communicating the basic description, function, appearance, dimensions, features, and installation of an item as manufactured by Collins Manufacturing Company. Because this drawing does not contain project specific information such as quantities, finishes, or options, it is not an approval drawing and does not require a signature. This drawing remains the property of Collins Manufacturing Company and must not be used against the interests of Collins Manufacturing Company.

Product Information

		Collins Manufacturing 2000 Bowser Road Cookeville, TN 38506	
Name: Empress Island			
Size: NTS	Part Number: 2125-34	Drawn By: Eng	
Prepared Date: 5/7/20	Revision Date: Date	Revision Number: Rev #	Sheet: 1 of 2

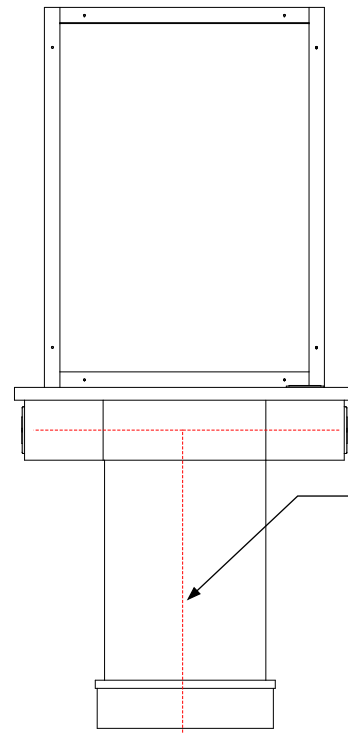
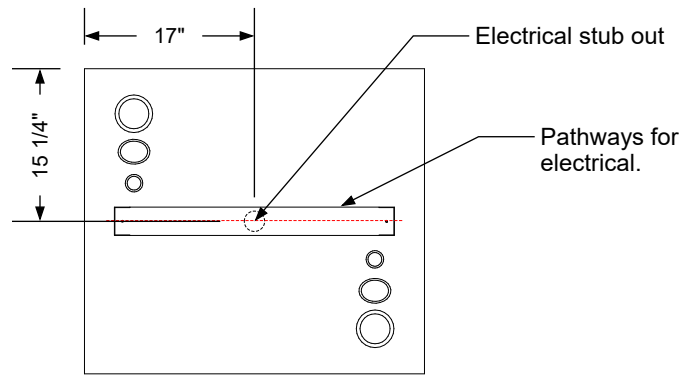

The electrician is responsible for connecting power to the fourplex outlets up from the floor along the indicated path. Provide a 20 amp, switched outlet for each student station (two per island).

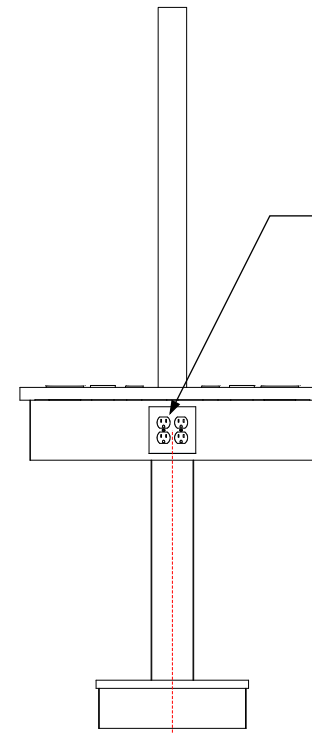

The island includes 20 amp fourplex outlets mounted below the countertop on both ends. The tools plug into these outlets.

Electrical stub out detail

Additional Information

Assembly required - yes
 Electrical required - yes
 Plumbing required - no
 Wall blocking required - no
 COM yardage/laminate usage - 34
 4"h laminated plywood toe
 Other (specify) - n/a
 Other (specify) - n/a

Specification Drawing

This **Specification Drawing** is intended for communicating the basic description, function, appearance, dimensions, features, and installation of an item as manufactured by Collins Manufacturing Company. Because this drawing does not contain project specific information such as quantities, finishes, or options, it is not an approval drawing and does not require a signature. This drawing remains the property of Collins Manufacturing Company and must not be used against the interests of Collins Manufacturing Company.

Product Information

		Collins Manufacturing 2000 Bowser Road Cookeville, TN 38506	
Name: Empress Island			
Size: NTS	Part Number: 2125-34	Drawn By: Eng	
Prepared Date: 5/7/20	Revision Date: Date	Revision Number: Rev #	Sheet: 2 of 2