



QSE DOUBLE BW

SKU:2203-48



A smart solution for your service area, the double backwash shampoo station features molded bottle wells for frequently used product and rear storage for towels. **Customize** the laminate options to match your decor.

TECHNICAL INFORMATION

- 48"W x 15"D x 27"H
- Two porcelain articulating shampoo bowls
- Two molded bottle wells
- Tilt out soiled towel bin
- Plumbing access below each bowl
- Specify shampoo bowl model when ordering

SHIPPING INFORMATION

Item generally ships via Freight(Truck) service

- Weight: 330 lbs
- Dimensions: 2 pallets

WARRANTY

3 Year:

- Molded urethane arms
- Cabinet drawer-slides

2 Year:

- All Shampoo Bowls
- Vacuum breakers

1 Year:

- All remaining components, unless noted otherwise

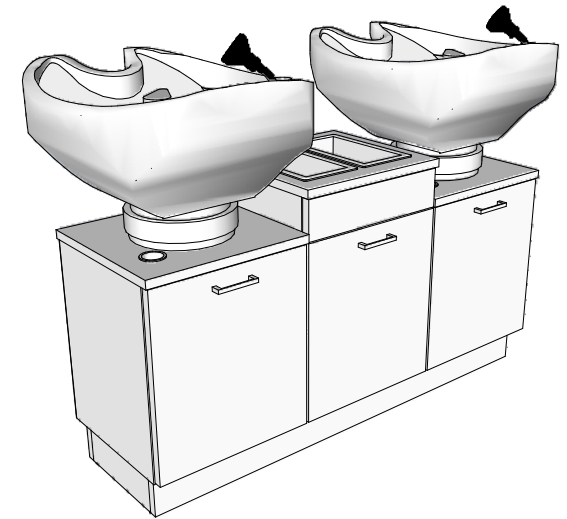
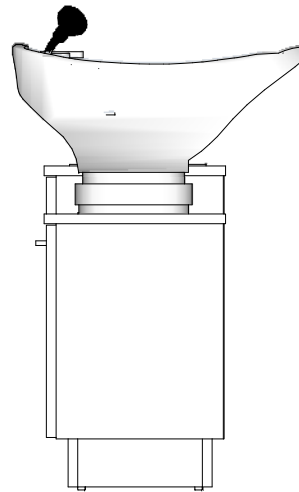
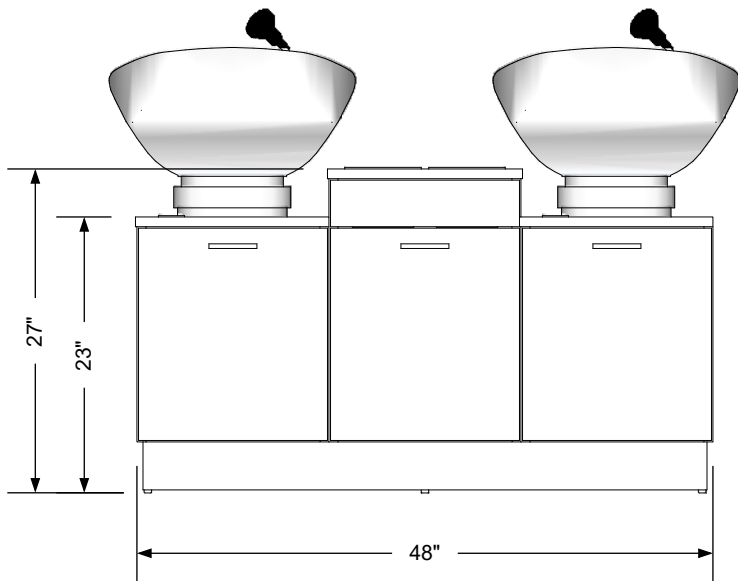
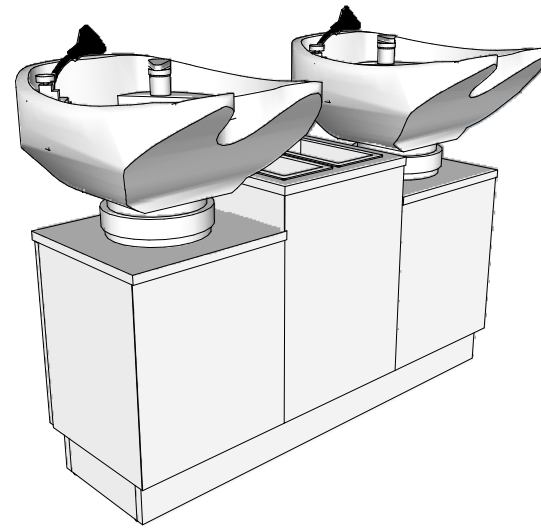
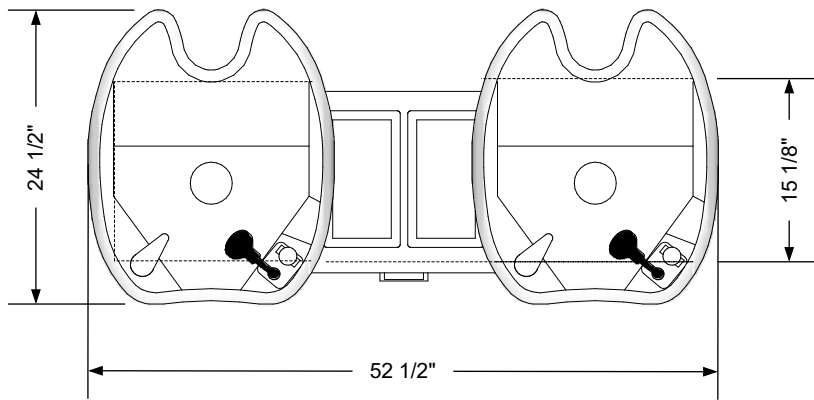

Additional Information

Assembly required - yes
 Electrical required - no
 Plumbing required - yes
 Wall blocking required - no
 COM yardage/laminate usage - 54 sf
 4" h laminated plywood toe + 1/4" h glides
 Other (specify) - n/a
 Other (specify) - n/a

Specification Drawing

This **Specification Drawing** is intended for communicating the basic description, function, appearance, dimensions, features, and installation of an item as manufactured by Collins Manufacturing Company. Because this drawing does not contain project specific information such as quantities, finishes, or options, it is not an approval drawing and does not require a signature. This drawing remains the property of Collins Manufacturing Company and must not be used against the interests of Collins Manufacturing Company.

Product Information

		Collins Manufacturing 2000 Bowser Road Cookeville, TN 38506	
Name: QSE Double Backwash			
Size: NTS	Part Number: 2203-48	Drawn By: Eng	
Prepared Date: 5/18/20	Revision Date: Date	Revision Number: Rev #	Sheet: 1 of 2

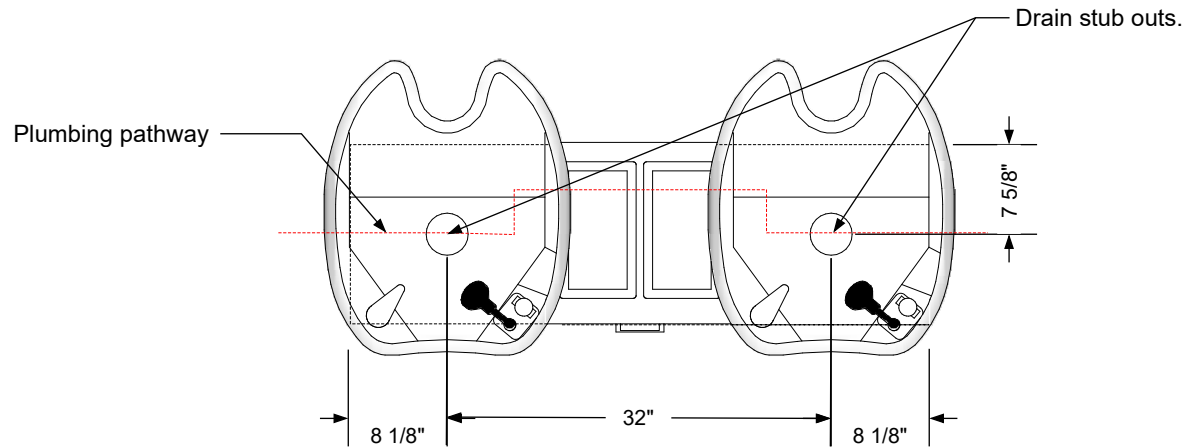

Multiple units may be plumbed through the ends and connected through units to either side.

Single units may be plumbed from the floor.

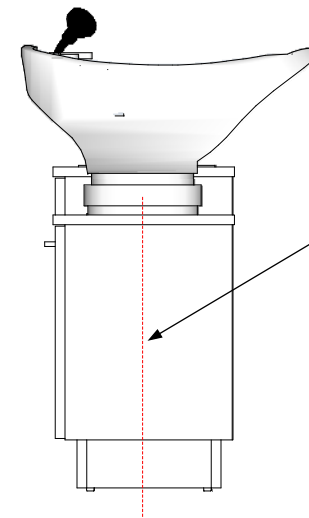
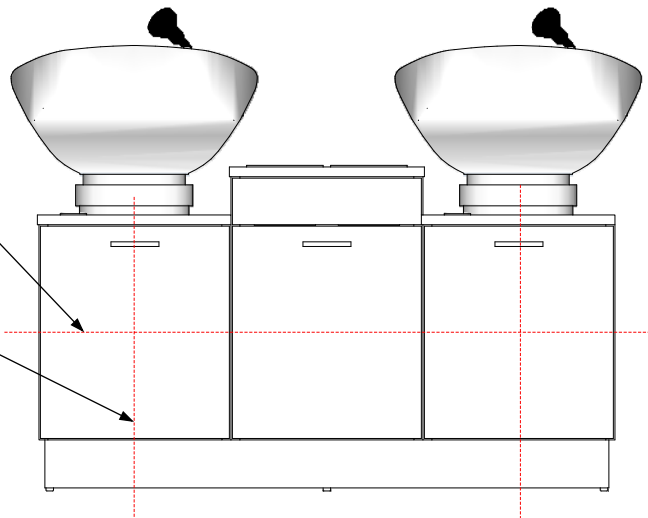

Plumbing pathway

Plumbing stub out detail

Additional Information

Assembly required - yes
 Electrical required - no
 Plumbing required - yes
 Wall blocking required - no
 COM yardage/laminate usage - 54 sf
 4" h laminated plywood toe + 1/4" h glides
 Other (specify) - n/a
 Other (specify) - n/a

Specification Drawing

This **Specification Drawing** is intended for communicating the basic description, function, appearance, dimensions, features, and installation of an item as manufactured by Collins Manufacturing Company. Because this drawing does not contain project specific information such as quantities, finishes, or options, it is not an approval drawing and does not require a signature. This drawing remains the property of Collins Manufacturing Company and must not be used against the interests of Collins Manufacturing Company.

Product Information

		Collins Manufacturing	
		2000 Bowser Road Cookeville, TN 38506	
Name: QSE Double Backwash			
Size: NTS	Part Number: 2203-48	Drawn By: Eng	
Prepared Date: 5/18/20	Revision Date: Date	Revision Number: Rev #	Sheet: 2 of 2