



VEECO STAINLESS NAIL TABLE

SKU:2260-36



A sleek, industrial manicure table for your salon or school. This heavy-duty stainless steel table comes with an 80 grit finish top that cleans easily, and wheels for easy movement from one room to another. With its simple yet modern design, this table is beautiful enough for any space and durable enough to withstand daily use at your salon or school environment.

TECHNICAL INFORMATION

- 36"W x 18"D x 30"H
- Industrial non-marring casters
- Padded rest not pictured

SHIPPING INFORMATION

Item generally ships via Freight(Truck) service

- Weight: 175 lbs
- Dimensions: 48"L x 32"W x 48"H

WARRANTY

3 Years:

- Ball-Bearing Drawer Slides
- Cabinet hinges

1 Year:

- All remaining components, unless noted otherwise, are guaranteed for a period of one year from the date of purchase.

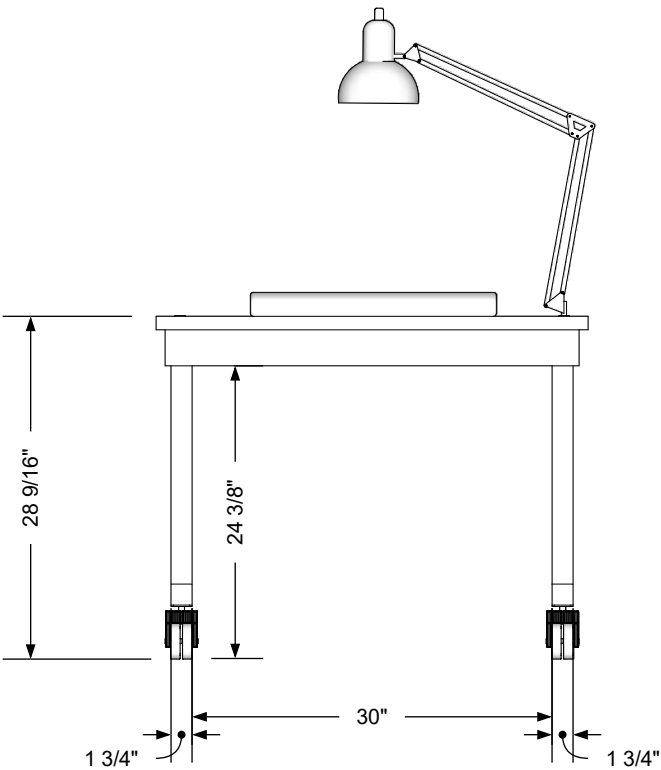
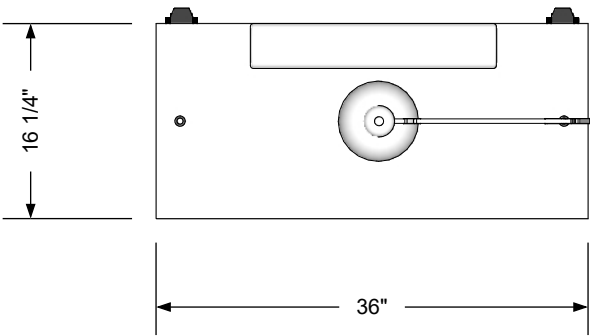

*Lamp Not Included.

Optional Lamp Mount Hole

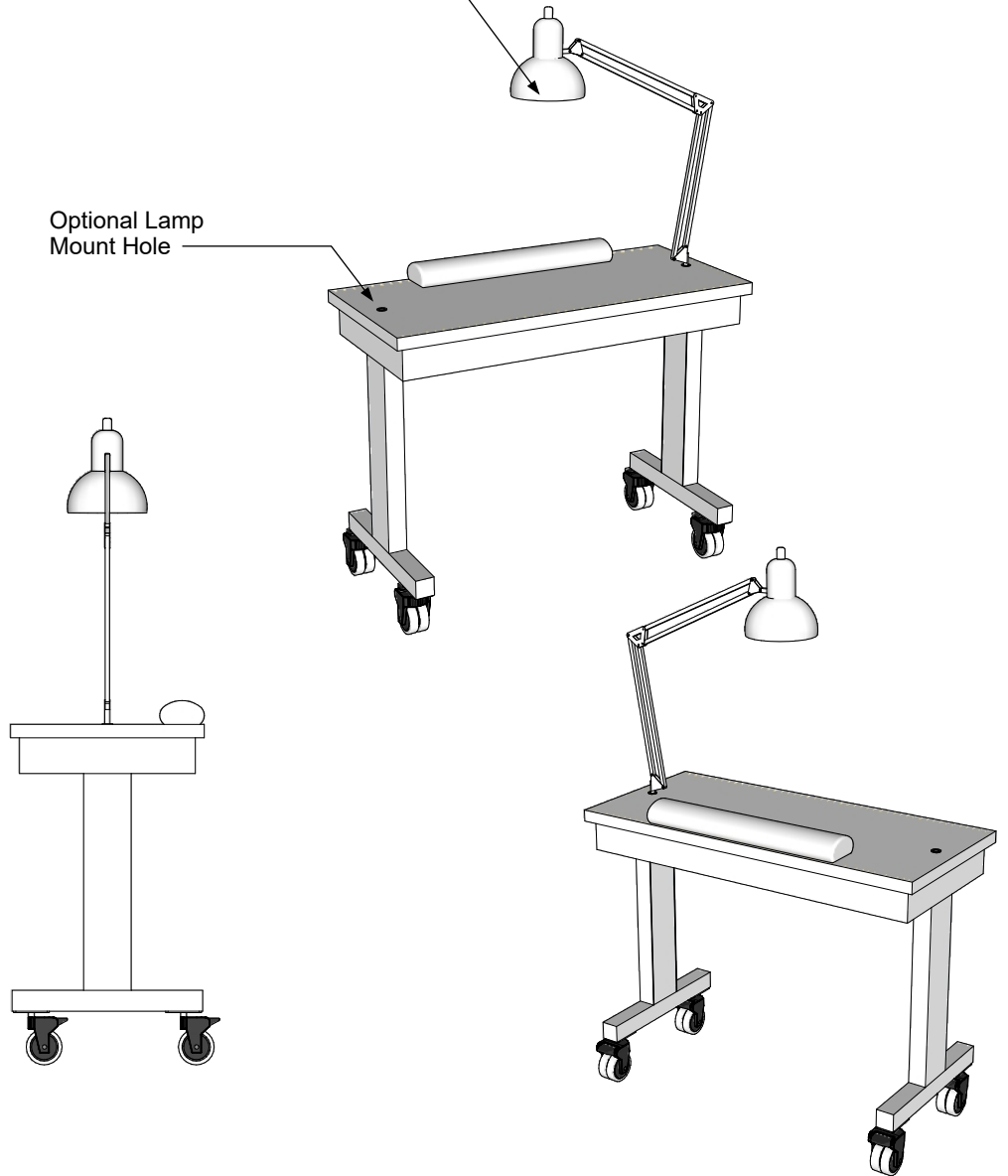

Additional Information

Assembly required - no
 Electrical required - yes
 Plumbing required - no
 Wall blocking required - no
 COM yardage/laminate usage - N/A
 4 1/2"h Twinwheel casters
 Other (specify) - n/a
 Other (specify) - n/a

Specification Drawing

This **Specification Drawing** is intended for communicating the basic description, function, appearance, dimensions, features, and installation of an item as manufactured by Collins Manufacturing Company. Because this drawing does not contain project specific information such as quantities, finishes, or options, it is not an approval drawing and does not require a signature. This drawing remains the property of Collins Manufacturing Company and must not be used against the interests of Collins Manufacturing Company.

Product Information

		Collins Manufacturing 2000 Bowser Road Cookeville, TN 38506	
Name: Veeco Stainless Nail Table			
Size: NTS	Part Number: 2260-36	Drawn By: Eng	
Prepared Date: 6/22/20	Revision Date: Date	Revision Number: Rev #	Sheet: 1 of 2

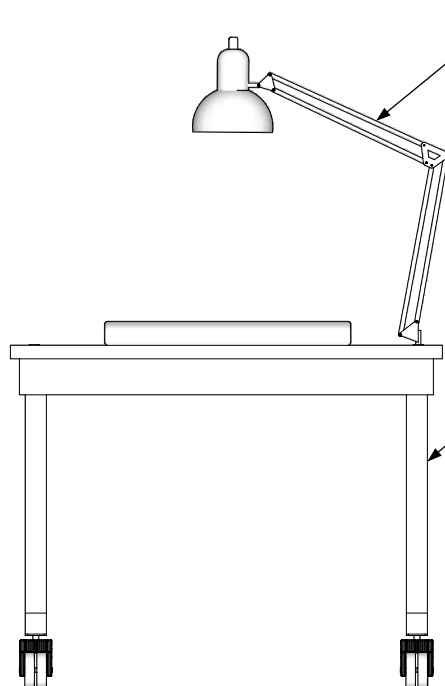
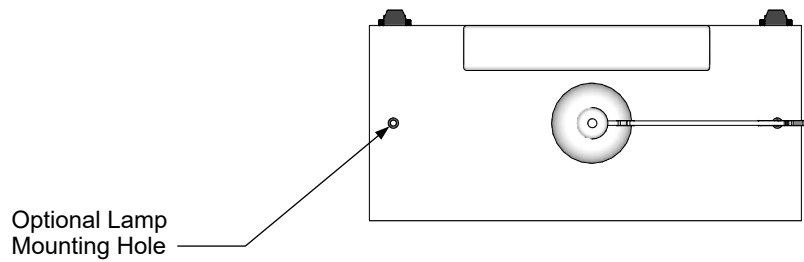

*Lamp Not Included.

There is no power strip or outlet included with this unit. Electrician to provide, install, and wire a 15 amp outlet installed in the wall or floor within reach of the lamp's 59" long cord.

Electrical stub out detail

Additional Information

Assembly required - no
 Electrical required - yes
 Plumbing required - no
 Wall blocking required - no
 COM yardage/laminate usage - n/a
 4 1/2" h Twinwheel casters
 Other (specify) - n/a
 Other (specify) - n/a

Specification Drawing

This **Specification Drawing** is intended for communicating the basic description, function, appearance, dimensions, features, and installation of an item as manufactured by Collins Manufacturing Company. Because this drawing does not contain project specific information such as quantities, finishes, or options, it is not an approval drawing and does not require a signature. This drawing remains the property of Collins Manufacturing Company and must not be used against the interests of Collins Manufacturing Company.

Product Information

		Collins Manufacturing 2000 Bowser Road Cookeville, TN 38506	
Name: Veeco Stainless Nail Table			
Size: NTS	Part Number: 2260-36	Drawn By: Eng	
Prepared Date: 6/22/20	Revision Date: Date	Revision Number: Rev #	Sheet: 2 of 2