



PETITE NAIL TABLE

SKU:2261-32

This beautiful Petite Manicure Table has a space saving design. Easily add manicure services to your menu and work space without compromising square footage. The casters allow for easy movement to another room, or out of the way when not in use.



TECHNICAL INFORMATION

- 32"W x 19"D x 30"H
- One drawer
- Padded rest
- Locking casters
- Lamp
- Perfect for small spaces

SHIPPING INFORMATION

Item generally ships via Freight(Truck) service

- Weight: 115 lbs
- Dimensions: 48"L x 32"W x 20"H

WARRANTY

3 Years:

- Ball-Bearing Drawer Slides
- Cabinet hinges

1 Year:

- All remaining components, unless noted otherwise, are guaranteed for a period of one year from the date of purchase.

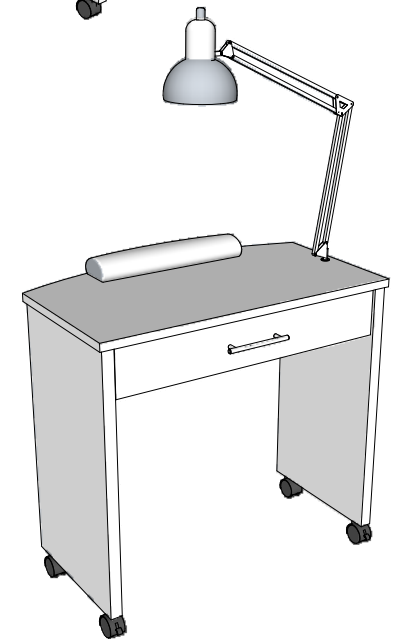
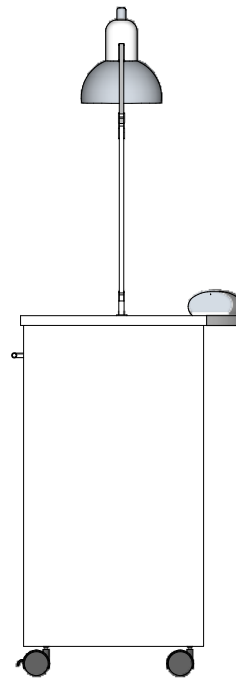
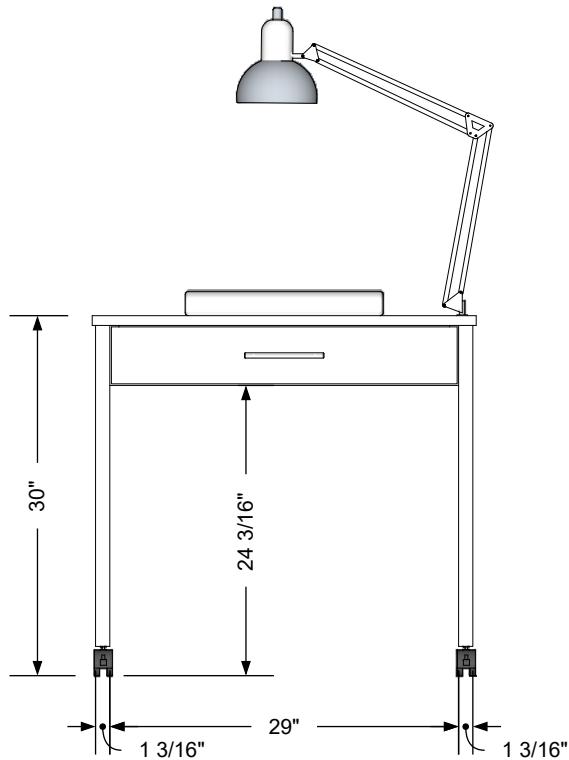
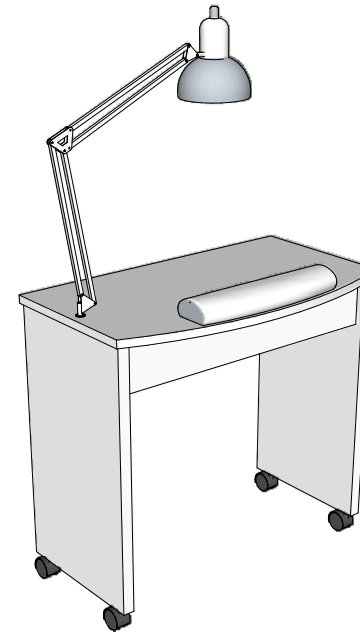
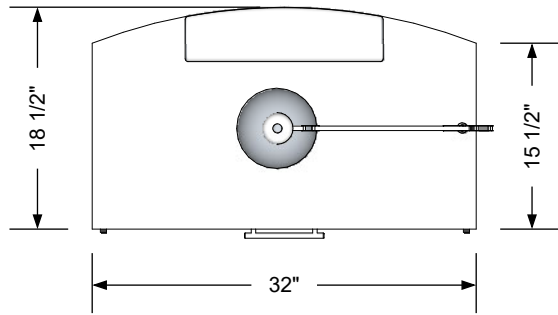

Additional Information

Assembly required - no
 Electrical required - yes
 Plumbing required - no
 Wall blocking required - no
 COM yardage/laminate usage - 29 sf
 2 1/2" h Twinwheel casters
 Other (specify) - n/a
 Other (specify) - n/a

Specification Drawing

This **Specification Drawing** is intended for communicating the basic description, function, appearance, dimensions, features, and installation of an item as manufactured by Collins Manufacturing Company. Because this drawing does not contain project specific information such as quantities, finishes, or options, it is not an approval drawing and does not require a signature. This drawing remains the property of Collins Manufacturing Company and must not be used against the interests of Collins Manufacturing Company.

Product Information

		Collins Manufacturing 2000 Bowser Road Cookeville, TN 38506	
		Name: Petite Nail Table	
Size: NTS	Part Number: 2261-32	Drawn By: Eng	
Prepared Date: 5/22/20	Revision Date: Date	Revision Number: Rev #	Sheet: 1 of 2

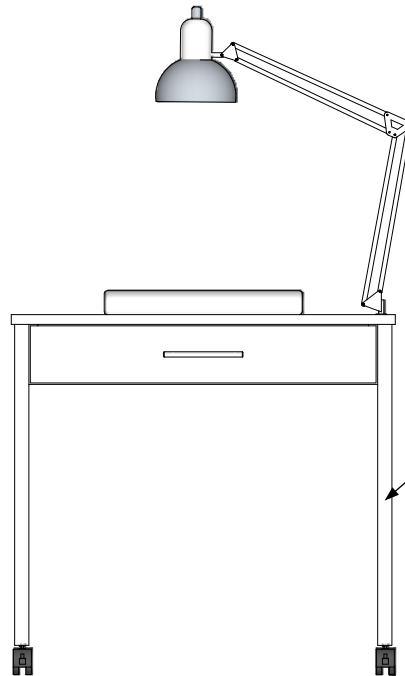
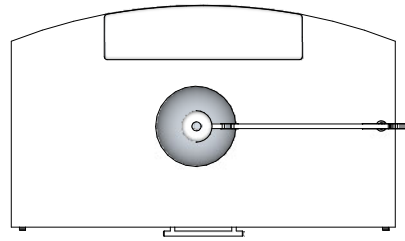

There is no power strip or outlet included with this unit. Electrician to provide, install, and wire a 15 amp outlet installed in the wall or floor within reach of the lamp's 59" long cord.

Electrical stub out detail

Additional Information

Assembly required - no
 Electrical required - yes
 Plumbing required - no
 Wall blocking required - no
 COM yardage/laminate usage - 29 sf
 2 1/2" h Twinwheel casters
 Other (specify) - n/a
 Other (specify) - n/a

Specification Drawing

This **Specification Drawing** is intended for communicating the basic description, function, appearance, dimensions, features, and installation of an item as manufactured by Collins Manufacturing Company. Because this drawing does not contain project specific information such as quantities, finishes, or options, it is not an approval drawing and does not require a signature. This drawing remains the property of Collins Manufacturing Company and must not be used against the interests of Collins Manufacturing Company.

Product Information

		Collins Manufacturing 2000 Bowser Road Cookeville, TN 38506	
Name: Petite Nail Table			
Size: NTS	Part Number: 2261-32	Drawn By: Eng	
Prepared Date: 5/22/20	Revision Date: Date	Revision Number: Rev #	Sheet: 2 of 2