



MAGNUM PEDICURE PLATFORM W/ PORTABLE FOOTSPA

SKU:2525-24

Magnum Pedicure Platform w/ pro foot basin featuring heat and massage.

TECHNICAL INFORMATION

- 24"W x 56"D x 35"H
- Platform
- Pro Foot Basin
- Upholstered chair top
- Footrest

SHIPPING INFORMATION

Item generally ships via Freight(Truck) service

- Weight: 200 lbs
- Dimensions: 60"L x 32"W x 36"H

WARRANTY

7.5 Years:

- Models 3500, 4500, 5550 Foot Operated Hydraulic Pumps

5 years:

- Collins Comfort Zone anti-fatigue mats
- All purpose and shampoo chair back reclining mechanisms

3 Years:

- BKB Electric Base
- Molded urethane arms
- Upholstery
- Ball-Bearing Drawer Slides
- Cabinet hinges

1 year:

- All remaining components, unless otherwise noted



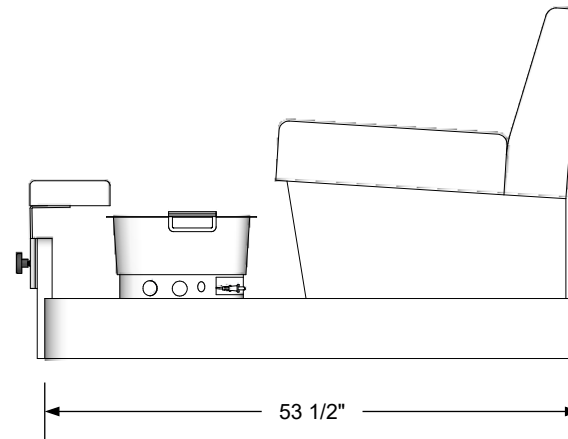
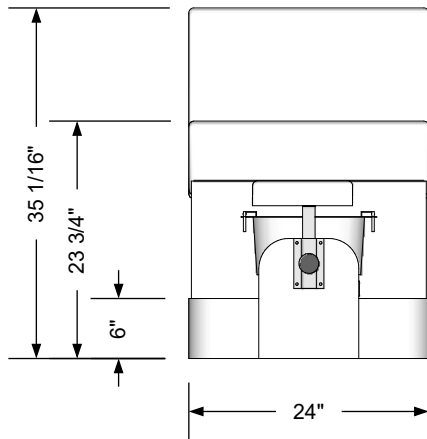
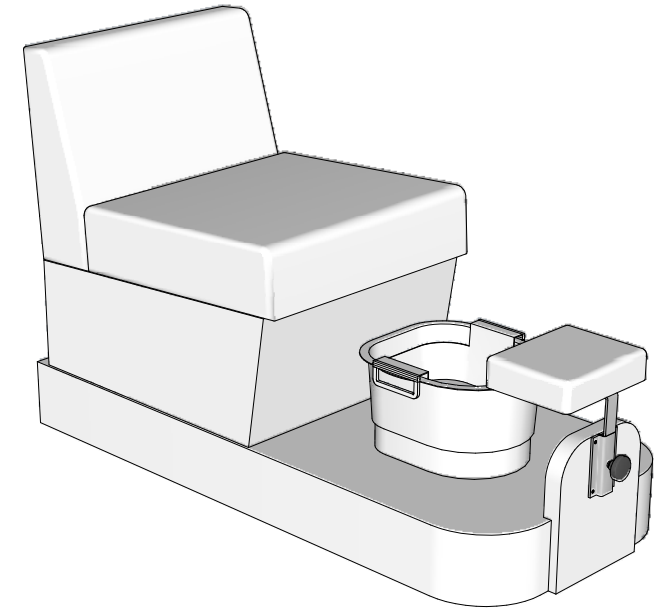
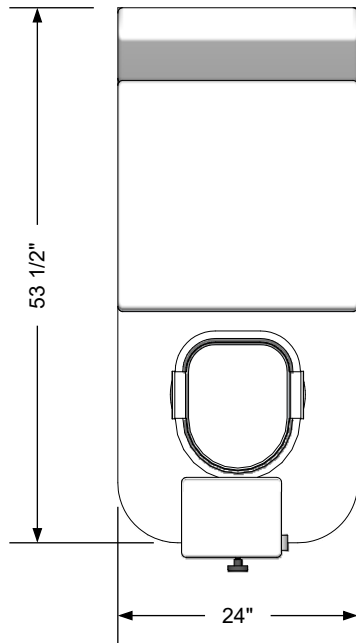

Additional Information

Assembly required - yes
 Electrical required - no
 Plumbing required - no
 Wall blocking required - no
 COM yardage/laminate usage - 3 yds/34 sf
 6"h laminated plywood base + 1/4"h glides
 Other (specify) - n/a
 Other (specify) - n/a

Specification Drawing

This **Specification Drawing** is intended for communicating the basic description, function, appearance, dimensions, features, and installation of an item as manufactured by Collins Manufacturing Company. Because this drawing does not contain project specific information such as quantities, finishes, or options, it is not an approval drawing and does not require a signature. This drawing remains the property of Collins Manufacturing Company and must not be used against the interests of Collins Manufacturing Company.

Product Information

		Collins Manufacturing 2000 Bowser Road Cookeville, TN 38506	
Name: Magnum Pedicure Platform With Footsie Bath			
Size: NTS	Part Number: 2525-24	Drawn By: Eng	
Prepared Date: 5/22/20	Revision Date: Date	Revision Number: Rev #	Sheet: 1 of 1