



10' ORGANIZER ASSEMBLY

SKU:2660-120

Maximize storage space with our 10' Organizer Assembly! This large, pre-configured system includes multiple cabinets to keep your belongings organized and accessible. Say goodbye to clutter and hello to efficiency.

TECHNICAL INFORMATION

- 112"W x 21"D x 84"H
 - featuring two 32" base cabinets (2661-32)
 - one 48" base cabinet with sink (2662-48)
 - two upper storage cabinets (2665-32)
 - one 48" upper cubby section (2664-48)
 - tall backsplashes

SHIPPING INFORMATION

Item generally ships via Freight(Truck) service

- Weight: 890 lbs
- Dimensions: 3 pallets

WARRANTY

3 Years:

- Ball-Bearing Drawer Slides
- Cabinet hinges

1 Year:

- All remaining components, unless noted otherwise, are guaranteed for a period of one year from the date of purchase.





Additional Information

Assembly required - yes
 Electrical required - no
 Plumbing required - yes
 Wall blocking required - yes
 COM yardage/laminate usage - 178 sf
 4" h laminated plywood toe + 1/4" h glides
 Other (specify) - n/a
 Other (specify) - n/a

Specification Drawing

This **Specification Drawing** is intended for communicating the basic description, function, appearance, dimensions, features, and installation of an item as manufactured by Collins Manufacturing Company. Because this drawing does not contain project specific information such as quantities, finishes, or options, it is not an approval drawing and does not require a signature. This drawing remains the property of Collins Manufacturing Company and must not be used against the interests of Collins Manufacturing Company.

Product Information

		Collins Manufacturing 2000 Bowser Road Cookeville, TN 38506	
Name: 10 Foot Organizer			
Size: NTS	Part Number: 2660-120	Drawn By: Eng	
Prepared Date: 5/29/20	Revision Date: Date	Revision Number: Rev #	Sheet: 1 of 4

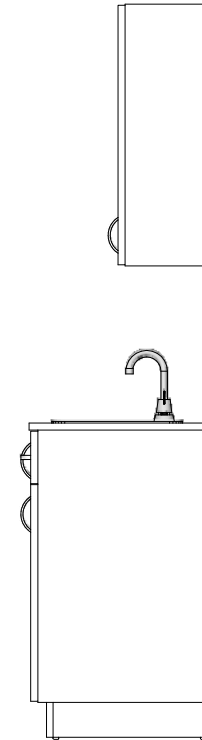
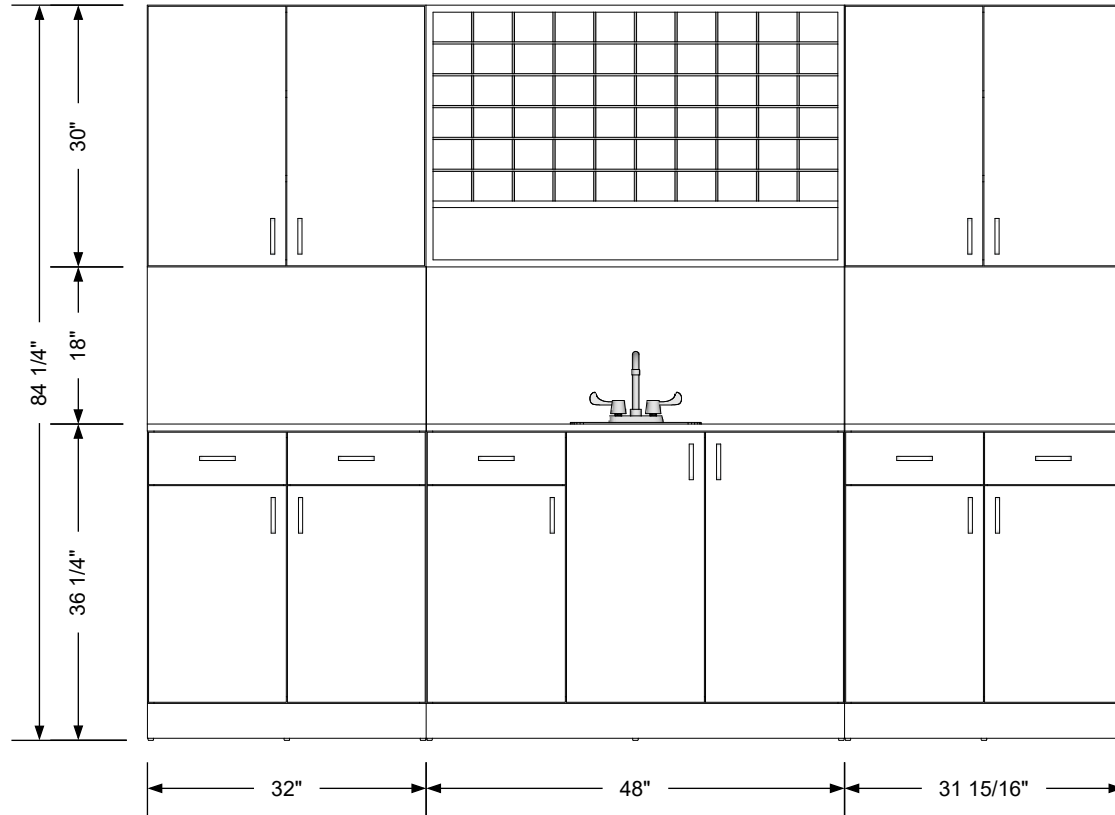
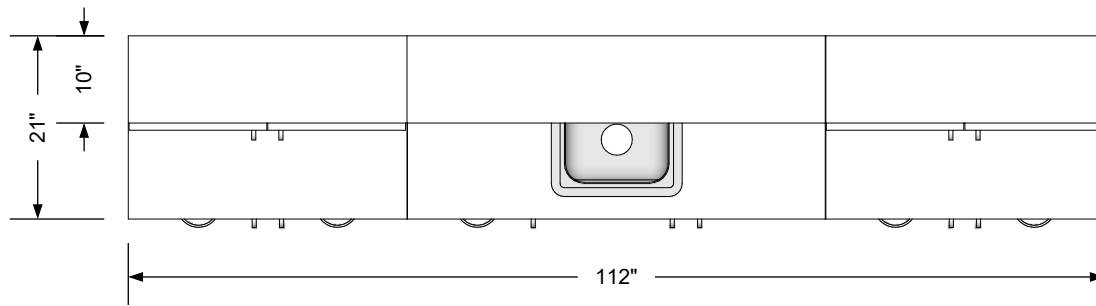

Additional Information

Assembly required - yes
 Electrical required - no
 Plumbing required - yes
 Wall blocking required - yes
 COM yardage/laminate usage - 178 sf
 4" h laminated plywood toe + 1/4" h glides
 Other (specify) - n/a
 Other (specify) - n/a

Specification Drawing

This **Specification Drawing** is intended for communicating the basic description, function, appearance, dimensions, features, and installation of an item as manufactured by Collins Manufacturing Company. Because this drawing does not contain project specific information such as quantities, finishes, or options, it is not an approval drawing and does not require a signature. This drawing remains the property of Collins Manufacturing Company and must not be used against the interests of Collins Manufacturing Company.

Product Information

		Collins Manufacturing 2000 Bowser Road Cookeville, TN 38506	
Name: 10 Foot Organizer			
Size: NTS	Part Number: 2660-120	Drawn By: Eng	
Prepared Date: 5/29/20	Revision Date: Date	Revision Number: Rev #	Sheet: 2 of 4

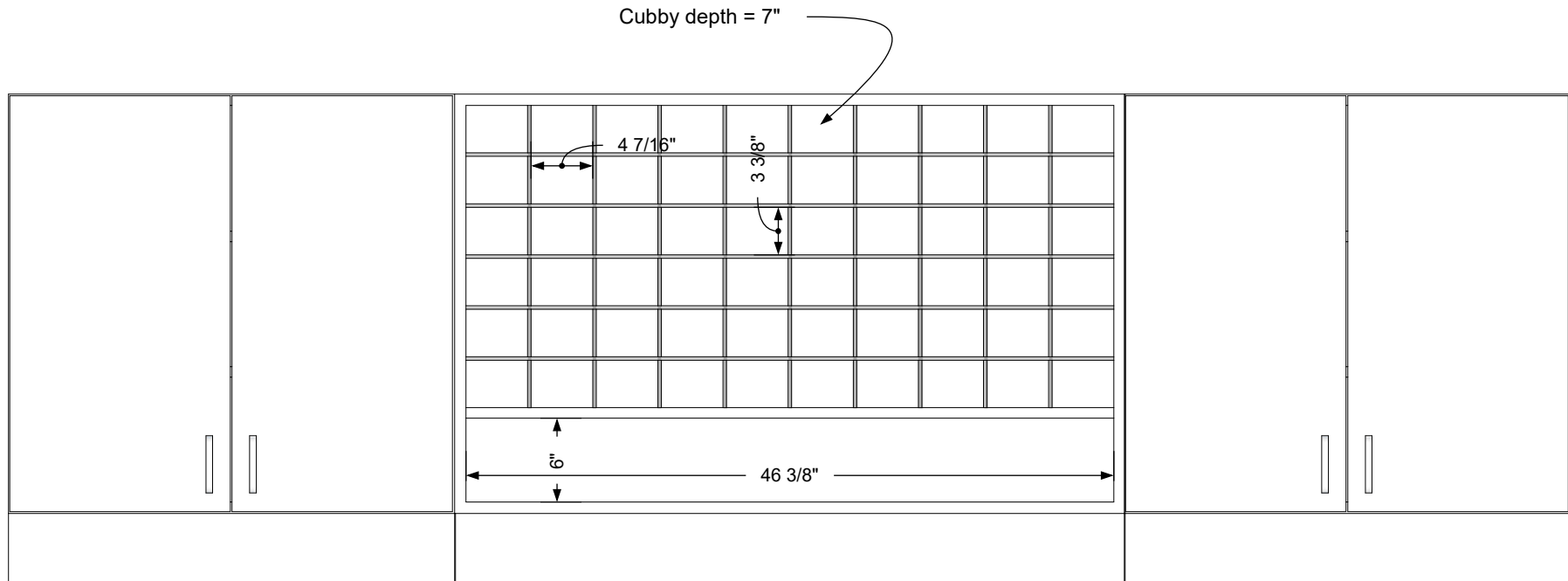

Cubby details

Additional Information

Assembly required - yes
 Electrical required - no
 Plumbing required - yes
 Wall blocking required - yes
 COM yardage/laminate usage - 178 sf
 4" h laminated plywood toe + 1/4" h glides
 Other (specify) - n/a
 Other (specify) - n/a

Specification Drawing

This **Specification Drawing** is intended for communicating the basic description, function, appearance, dimensions, features, and installation of an item as manufactured by Collins Manufacturing Company. Because this drawing does not contain project specific information such as quantities, finishes, or options, it is not an approval drawing and does not require a signature. This drawing remains the property of Collins Manufacturing Company and must not be used against the interests of Collins Manufacturing Company.

Product Information

		Collins Manufacturing 2000 Bowser Road Cookeville, TN 38506	
Name: 10 Foot Organizer			
Size: NTS	Part Number: 2660-120	Drawn By: Eng	
Prepared Date: 5/29/20	Revision Date: Date	Revision Number: Rev #	Sheet: 3 of 4

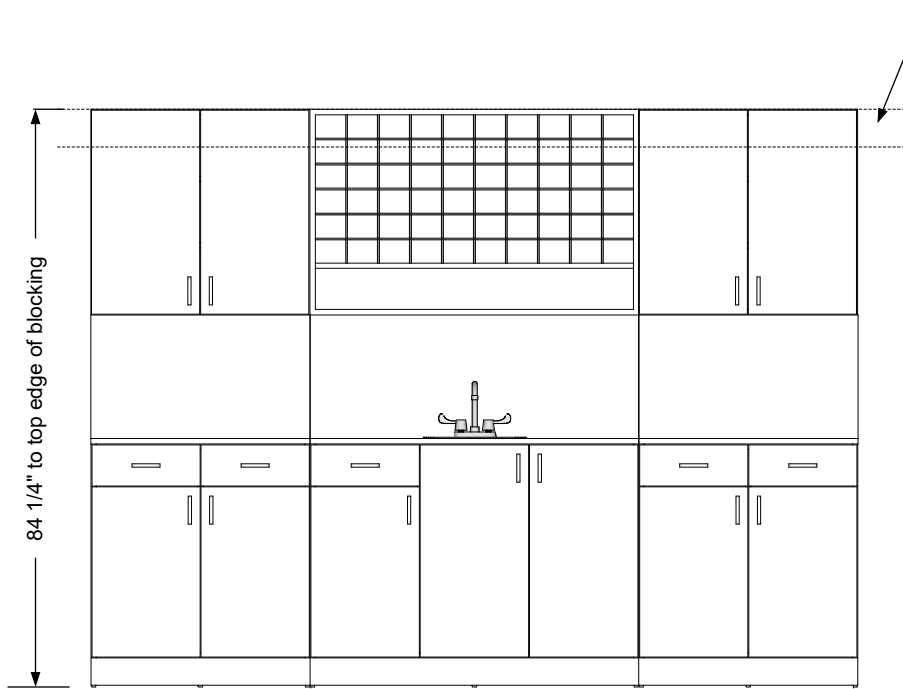

Blocking detail

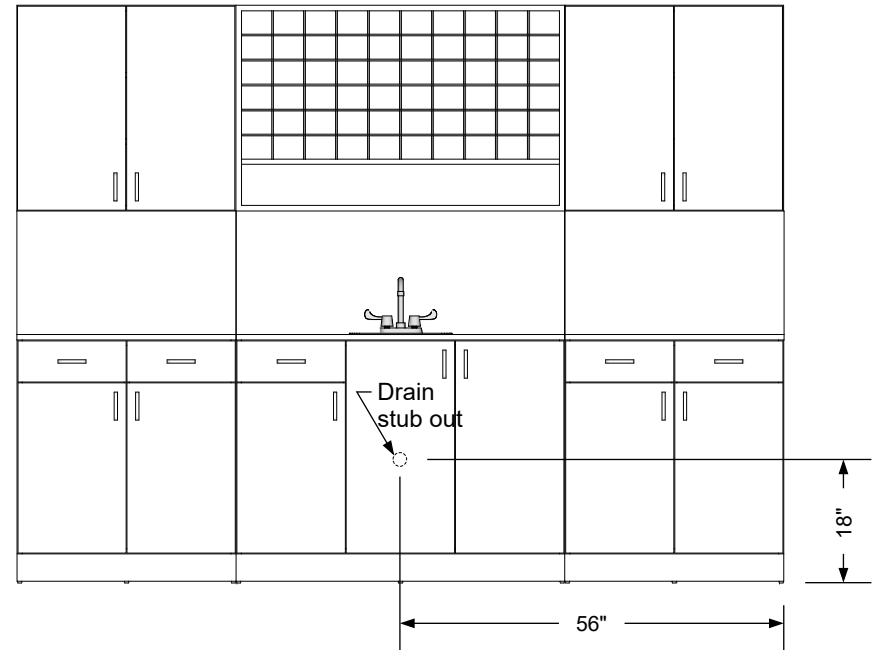

Plumbing stub out detail

Additional Information

Assembly required - yes
 Electrical required - no
 Plumbing required - yes
 Wall blocking required - yes
 COM yardage/laminate usage - 178 sf
 4"h laminated plywood toe + 1/4"h glides
 Other (specify) - n/a
 Other (specify) - n/a

Specification Drawing

This **Specification Drawing** is intended for communicating the basic description, function, appearance, dimensions, features, and installation of an item as manufactured by Collins Manufacturing Company. Because this drawing does not contain project specific information such as quantities, finishes, or options, it is not an approval drawing and does not require a signature. This drawing remains the property of Collins Manufacturing Company and must not be used against the interests of Collins Manufacturing Company.

Product Information

		Collins Manufacturing 2000 Bowser Road Cookeville, TN 38506	
Name: 10 Foot Organizer			
Size: NTS	Part Number: 2660-120	Drawn By: Eng	
Prepared Date: 5/29/20	Revision Date: Date	Revision Number: Rev #	Sheet: 4 of 4