



QSE-EDU BARBER STATION

SKU:2314-60



The traditionally designed QSE Barber Station is a great match for any barbershop. It features a top built-in tool holder, storage cabinets and drawers to hold everything you need for a successful day at work.

By selecting our Quick Ship laminate options, this station can ship out to you sooner.

TECHNICAL INFORMATION

- 60"W x 15"D x 75"H
- Two drawers
- Two storage cabinets with industrial hinges
- Top mounted tool holders
- •
- Quad electrical outlet
- Plumbing access doors
- CB19 ABS shampoo bowl
- 36" x 60" mirror

SHIPPING INFORMATION

Item generally ships via Freight(Truck) service

- Weight: 360 lbs
- Dimensions: 72"L x 32"W x 48"H

WARRANTY

3 Year:

- Molded urethane arms
- Cabinet drawer-slides

2 Year:

- All Shampoo Bowls
- Vacuum breakers

1 Year:

- All remaining components, unless noted otherwise

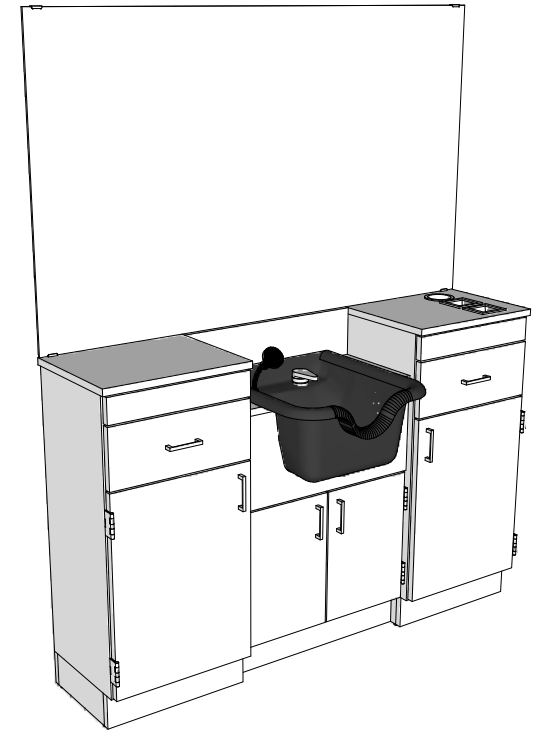
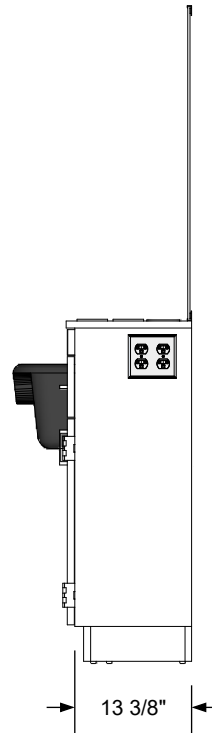
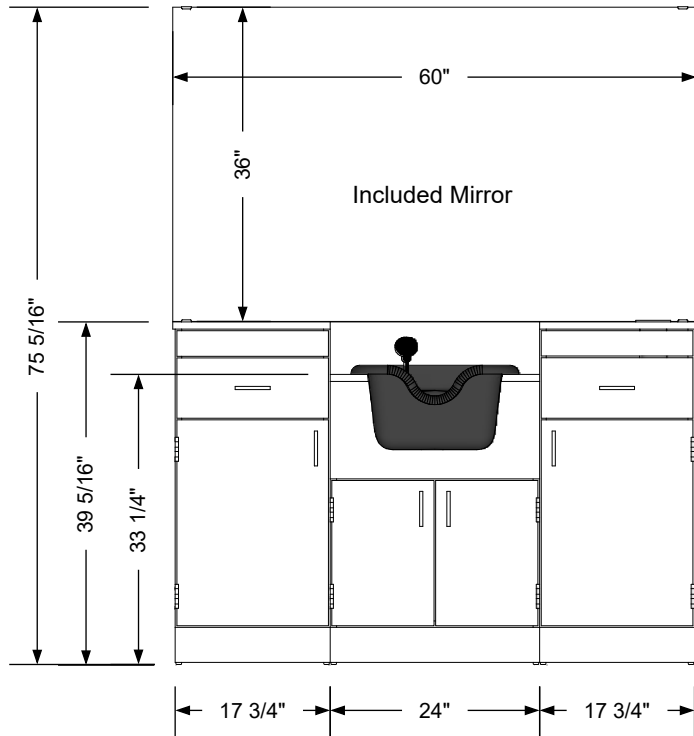
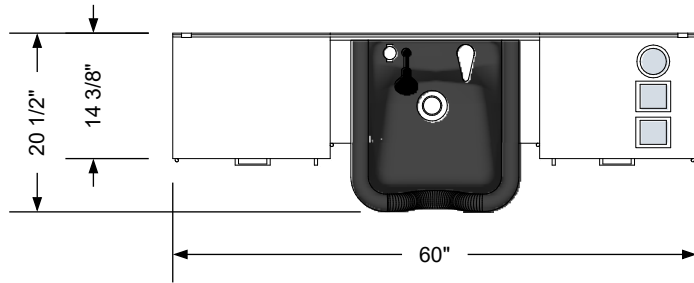

Additional Information

Assembly required - yes
 Electrical required - yes
 Plumbing required - yes
 Wall blocking required - no
 COM yardage/laminate usage - 56 sf
 4" h laminated plywood toe + 1/4" h glides
 Other (specify) - n/a
 Other (specify) - n/a

Specification Drawing

This **Specification Drawing** is intended for communicating the basic description, function, appearance, dimensions, features, and installation of an item as manufactured by Collins Manufacturing Company. Because this drawing does not contain project specific information such as quantities, finishes, or options, it is not an approval drawing and does not require a signature. This drawing remains the property of Collins Manufacturing Company and must not be used against the interests of Collins Manufacturing Company.

Product Information

		Collins Manufacturing 2000 Bowser Road Cookeville, TN 38506	
Name: QSE-edu Barber Station			
Size: NTS	Part Number: 2314-60	Drawn By: Eng	
Prepared Date: 6/5/20	Revision Date: Date	Revision Number: Rev #	Sheet: 1 of 2

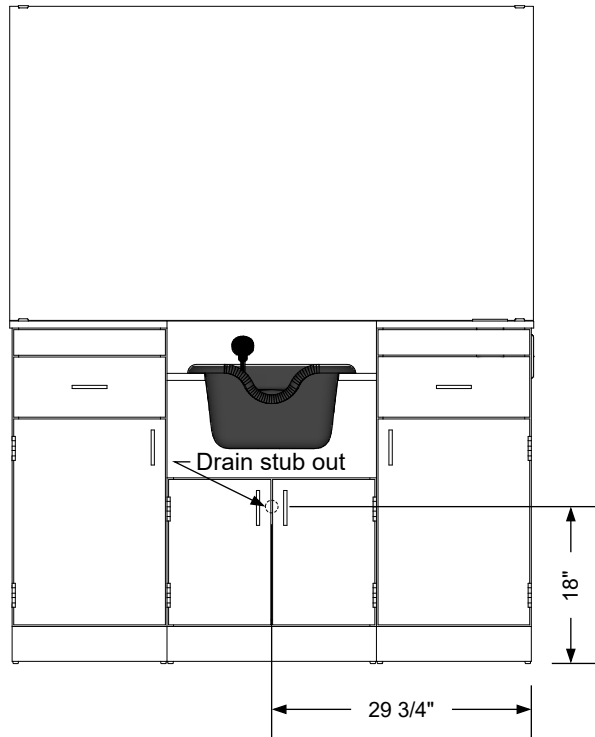
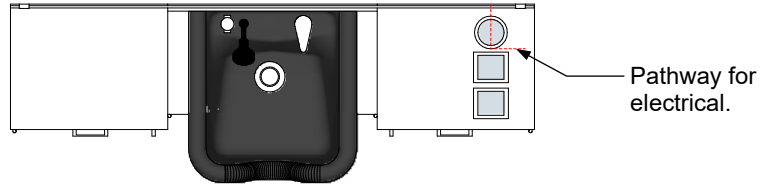

Plumbing stub out detail

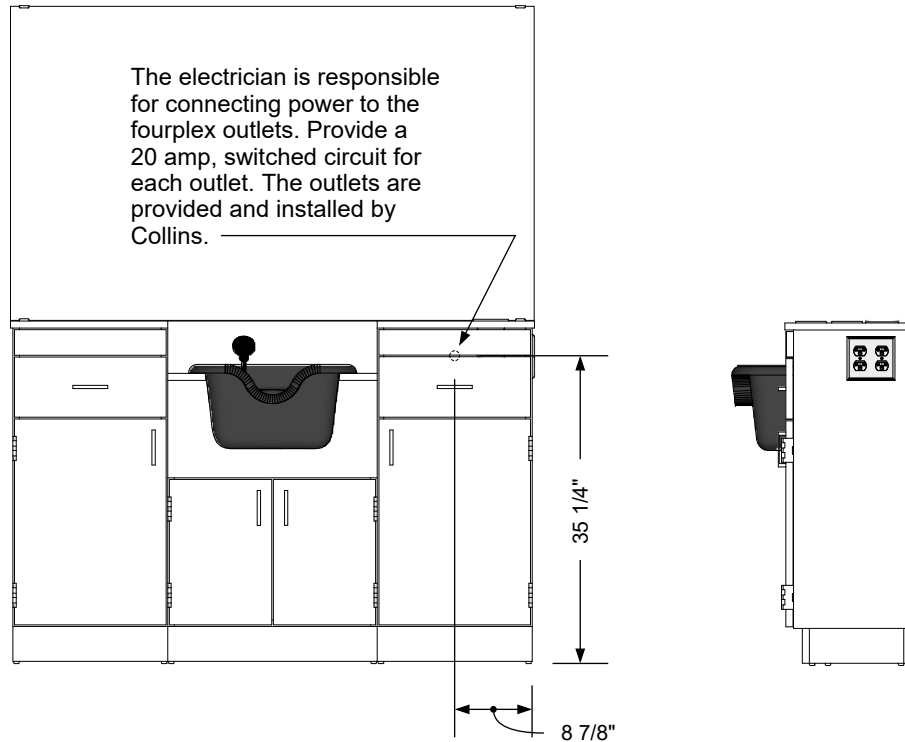

Electrical stub out detail

Additional Information

Assembly required - yes
 Electrical required - yes
 Plumbing required - yes
 Wall blocking required - no
 COM yardage/laminate usage - 56 sf
 4"h laminated plywood toe + 1/4"h glides
 Other (specify) - n/a
 Other (specify) - n/a

Specification Drawing

This **Specification Drawing** is intended for communicating the basic description, function, appearance, dimensions, features, and installation of an item as manufactured by Collins Manufacturing Company. Because this drawing does not contain project specific information such as quantities, finishes, or options, it is not an approval drawing and does not require a signature. This drawing remains the property of Collins Manufacturing Company and must not be used against the interests of Collins Manufacturing Company.

Product Information

		Collins Manufacturing 2000 Bowser Road Cookeville, TN 38506	
Name: QSE-edu Barber Station			
Size: NTS	Part Number: 2314-60	Drawn By: Eng	
Prepared Date: 6/5/20	Revision Date: Date	Revision Number: Rev #	Sheet: 2 of 2