



FREE-STANDING SINGLE SIDED COMBO DESK

SKU:2459-36



This Free-Standing salon workstation is the perfect all-in-one solution to create, style and teach from within your school.

Includes a mannequin holder, built in tool holders for easy access to all of your products, convenient electrical outlets so you can power up your tools, stainless steel foot support, and shelving for storage.

*3 single units shown side-by-side.

TECHNICAL INFORMATION

- 36"W x 21"D x 34"H
- Radius corners on writing surface
- Mannequin clamp support
- Storage cubby
- Curling iron holder
- Flat iron holder
- Fourplex outlet
- Continuous electrical chase
- S/S tubular foot support
- Available in 36" or 40" lengths

SHIPPING INFORMATION

Item generally ships via Freight(Truck) service

- Weight: 150 lbs
- Dimensions: 48"L x 32"W x 42"H

WARRANTY

3 Years:

- Ball-Bearing Drawer Slides
- Cabinet hinges

1 Year:

- All remaining components, unless noted otherwise, are guaranteed for a period of one year from the date of purchase.

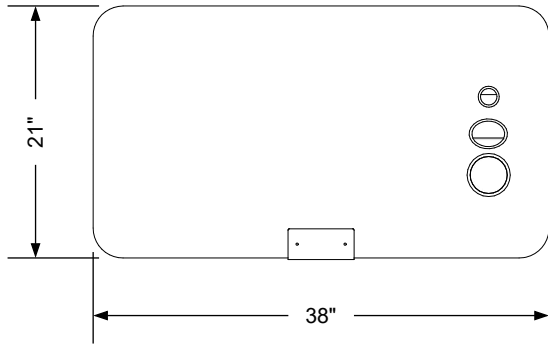

Note:
 One single unit is shown for dimensions and illustrate what is included in the unit price. In practice, configurations almost always use two stations as a minimum. The configurations may be arranged for multiple students limited only by the student spacing and size of the room. In those situations, the countertops are made into longer sections to eliminate seams and redundant support legs are deleted. The student spacing will remain unchanged.

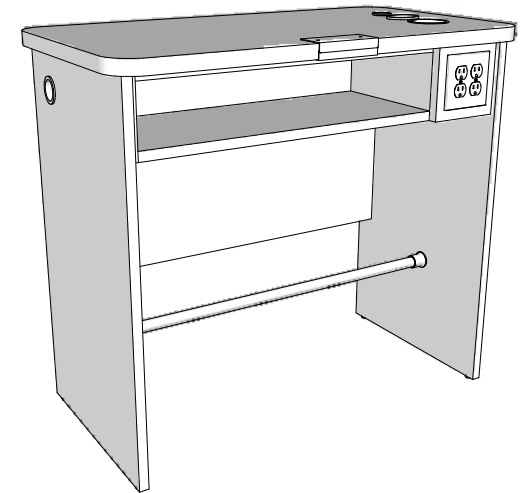
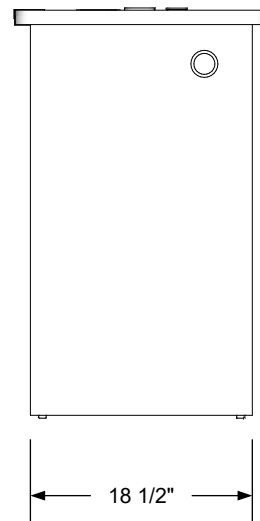
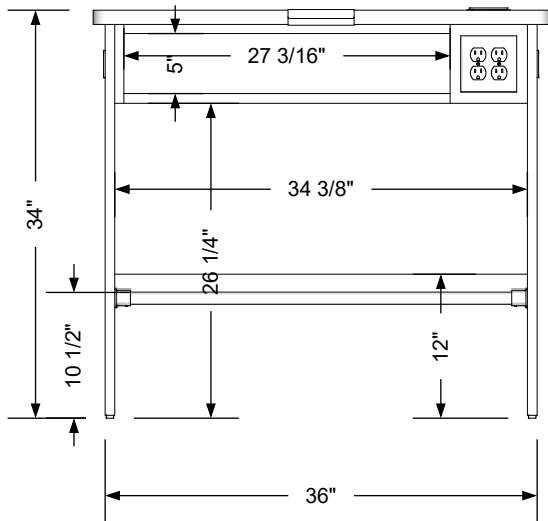
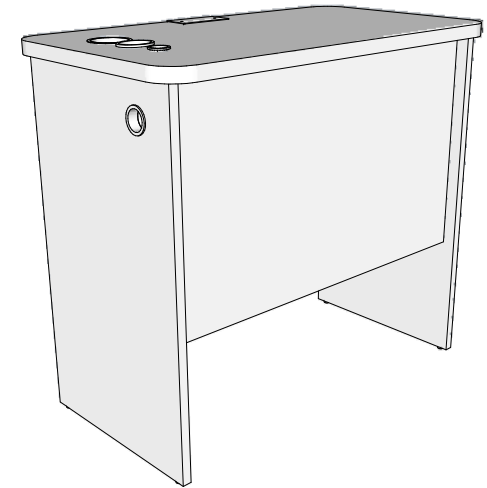

Additional Information

Assembly required - yes
 Electrical required - yes
 Plumbing required - no
 Wall blocking required - no
 COM yardage/laminate usage - 54 sf
 Laminated support legs + 1/4" h glides
 Other (specify) - n/a
 Other (specify) - n/a

Specification Drawing

This **Specification Drawing** is intended for communicating the basic description, function, appearance, dimensions, features, and installation of an item as manufactured by Collins Manufacturing Company. Because this drawing does not contain project specific information such as quantities, finishes, or options, it is not an approval drawing and does not require a signature. This drawing remains the property of Collins Manufacturing Company and must not be used against the interests of Collins Manufacturing Company.

Product Information

collins		Collins Manufacturing 2000 Bowser Road Cookeville, TN 38506	
Name: Free-Standing Single-Sided Combo Desk - 36			
Size: NTS	Part Number: 2459-36	Drawn By: Eng	
Prepared Date: 6/15/20	Revision Date: Date	Revision Number: Rev #	Sheet: 1 of 2

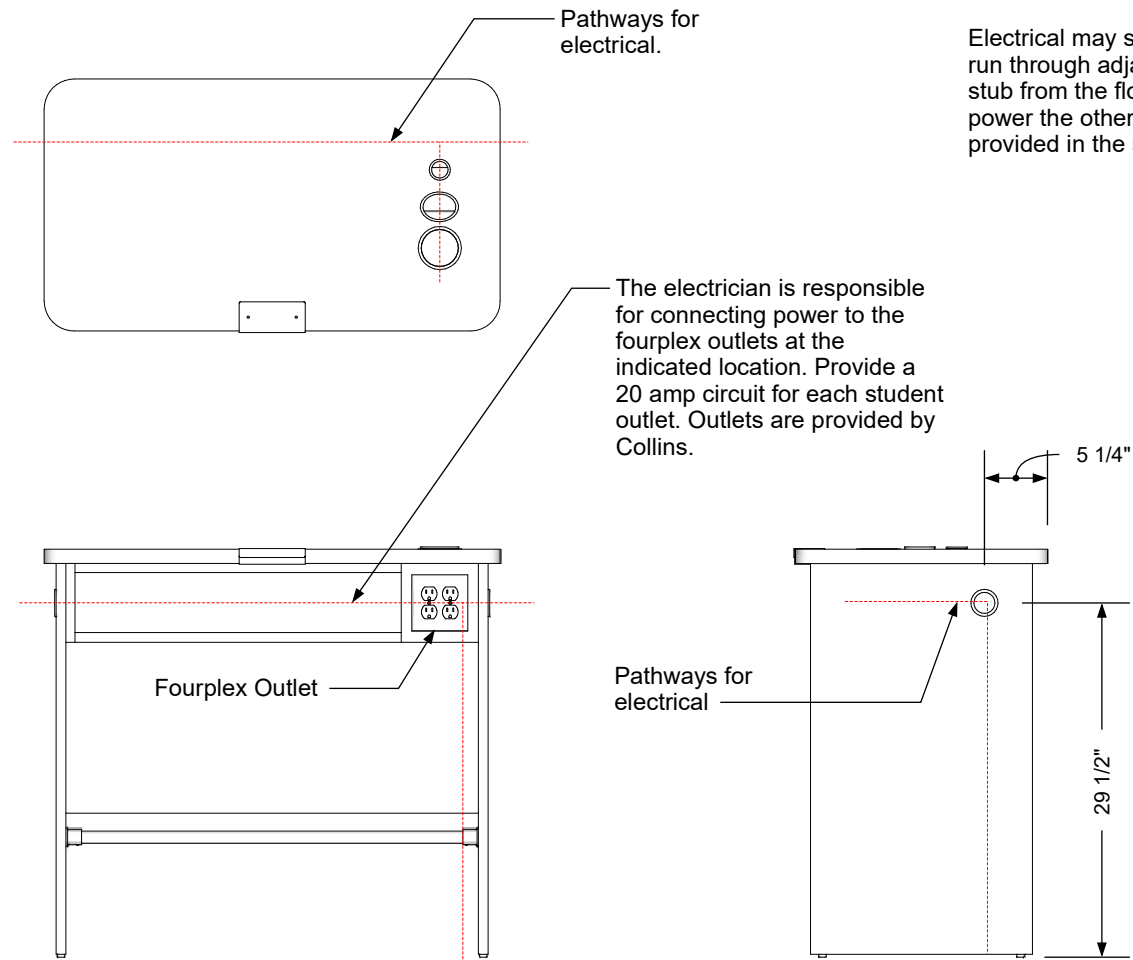

Electrical stub out detail

Additional Information

Assembly required - yes
 Electrical required - yes
 Plumbing required - no
 Wall blocking required - no
 COM yardage/laminate usage - 54 sf
 Laminated support legs + 1/4"h glides
 Other (specify) - n/a
 Other (specify) - n/a

Specification Drawing

This **Specification Drawing** is intended for communicating the basic description, function, appearance, dimensions, features, and installation of an item as manufactured by Collins Manufacturing Company. Because this drawing does not contain project specific information such as quantities, finishes, or options, it is not an approval drawing and does not require a signature. This drawing remains the property of Collins Manufacturing Company and must not be used against the interests of Collins Manufacturing Company.

Product Information

		Collins Manufacturing 2000 Bowser Road Cookeville, TN 38506	
		Name: Free-Standing Single-Sided Combo Desk - 36	
Size: NTS	Part Number: 2459-36	Drawn By: Eng	
Prepared Date: 6/15/20	Revision Date: Date	Revision Number: Rev #	Sheet: 2 of 2