



STAINLESS MANNEQUIN LEDGE

SKU:2465-36

Display your mannequin heads and make them easy to retrieve with our Wall Mounted Stainless Steel Mannequin Ledge. Designed to fit in a variety of spaces, this ledge is made of stainless steel which makes it easy to clean and maintain.



TECHNICAL INFORMATION

- 36"W x 18"D x 34"H
- Wood core
- Built in mannequin clamp protection
- Properly spaced countertop brackets
- Ordered in sections of 36" x 40" in length but may ship in longer sections like pictured

SHIPPING INFORMATION

Item generally ships via Freight(Truck) service

- Weight: 125 lbs
- Dimensions: 42"L x 32"W x 24"H

WARRANTY

3 Years:

- Ball-Bearing Drawer Slides
- Cabinet hinges

1 Year:

- All remaining components, unless noted otherwise, are guaranteed for a period of one year from the date of purchase.

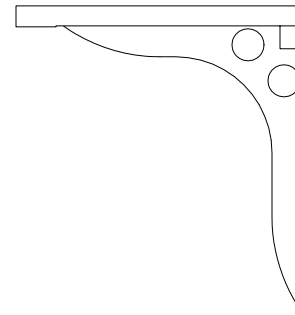
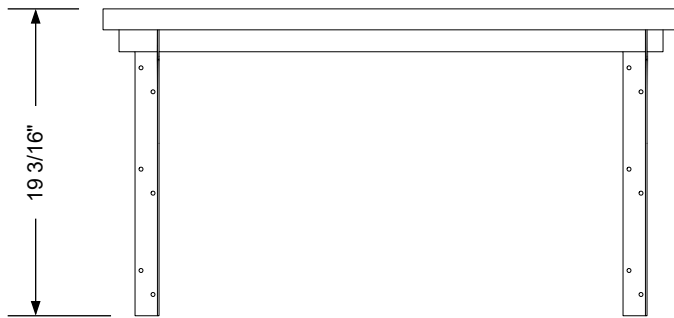
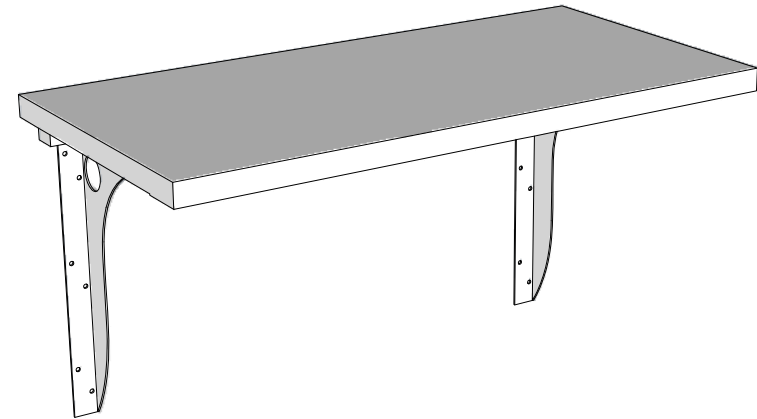
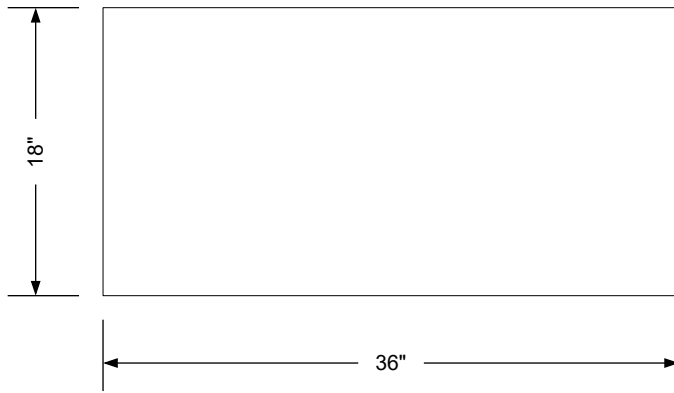

Note:

One single unit is shown for dimensions and illustrate what is included in the unit price. In practice, configurations almost always use two stations as a minimum. The configurations may be arranged for multiple students limited only by the student spacing and size of the room. The larger configurations are achieved by producing in single, double, and triple length versions. In those situations, the countertops are made into longer sections to eliminate seams and redundant countertop supports are deleted. The student spacing will remain unchanged.

Additional Information

Assembly required - yes
 Electrical required - no
 Plumbing required - no
 Wall blocking required - no
 COM yardage/laminate usage - n/a
 Metal wall-mounted brackets
 Other (specify) - n/a
 Other (specify) - n/a

Specification Drawing

This **Specification Drawing** is intended for communicating the basic description, function, appearance, dimensions, features, and installation of an item as manufactured by Collins Manufacturing Company. Because this drawing does not contain project specific information such as quantities, finishes, or options, it is not an approval drawing and does not require a signature. This drawing remains the property of Collins Manufacturing Company and must not be used against the interests of Collins Manufacturing Company.

Product Information

		Collins Manufacturing 2000 Bowser Road Cookeville, TN 38506	
Name: Stainless Mannequin Ledge - 36			
Size: NTS	Part Number: 2465-36	Drawn By: Eng	
Prepared Date: 7/2/20	Revision Date: Date	Revision Number: Rev #	Sheet: 1 of 2

Note:
 Blocking is shown for the top of the counter being at 34" above the floor. This is the typical height for these stations. If a different height is preferred, adjust blocking height as needed.

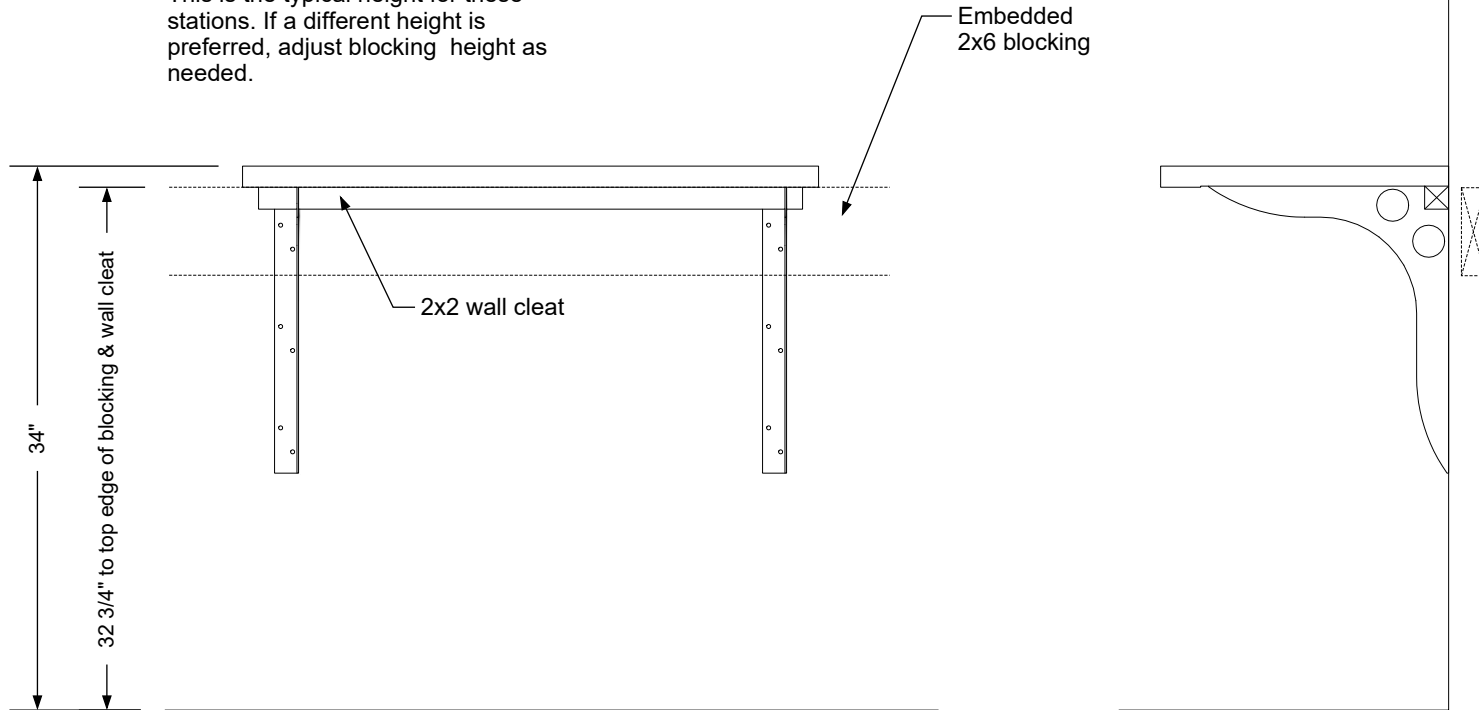

Wall blocking detail

Additional Information

Assembly required - yes
 Electrical required - no
 Plumbing required - no
 Wall blocking required - no
 COM yardage/laminate usage - n/a
 Metal wall-mounted brackets
 Other (specify) - n/a
 Other (specify) - n/a

Specification Drawing

This **Specification Drawing** is intended for communicating the basic description, function, appearance, dimensions, features, and installation of an item as manufactured by Collins Manufacturing Company. Because this drawing does not contain project specific information such as quantities, finishes, or options, it is not an approval drawing and does not require a signature. This drawing remains the property of Collins Manufacturing Company and must not be used against the interests of Collins Manufacturing Company.

Product Information

		Collins Manufacturing 2000 Bowser Road Cookeville, TN 38506	
Name: Stainless Mannequin Ledge - 36			
Size: NTS	Part Number: 2465-36	Drawn By: Eng	
Prepared Date: 7/2/20	Revision Date: Date	Revision Number: Rev #	Sheet: 2 of 2