



## DOUBLE SIDED MANNEQUIN COMBO DESK/MANNEQUIN WORKSTATION FOR TWO STUDENTS

SKU:2460-36



This salon workstation is the perfect all-in-one solution to create, style and teach from within your school. Features double sided shelving to accommodate two students.

Includes a mannequin holder, built in tool holders for easy access to all of your products, convenient electrical outlets so you can power up your tools, and shelving for storage.

### TECHNICAL INFORMATION

- 36"W x 30"D x 34"H
- Radius corners work surface
- Two mannequin clamp supports
- Two storage cubbies
- Two fourplexes with electrical chase
- Two curling iron holders
- Two flat iron holders
- Two blow dryer holders
- Student kit storage shelf with protective S/S edging
- Available in 36" or 40" lengths

### SHIPPING INFORMATION

Item generally ships via Freight(Truck) service

- Weight: 250 lbs
- Dimensions: 48"L x 36"W x 42"H

### WARRANTY

#### 3 Years:

- Ball-Bearing Drawer Slides
- Cabinet hinges

#### 1 Year:

- All remaining components, unless noted otherwise, are guaranteed for a period of one year from the date of purchase.

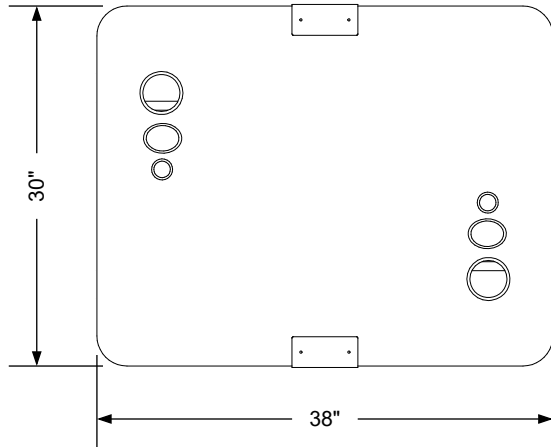

Note:  
 One single unit is shown for dimensions and to illustrate what is included in the unit price. In practice, configurations almost always use two stations as a minimum. The configurations may be arranged for multiple students limited only by the student spacing and size of the room. The larger configurations are achieved by using multiple supports and stretchers and spanning them with single, double, and triple length countertops

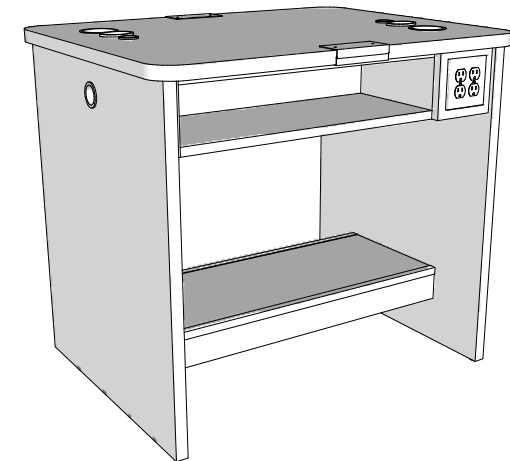
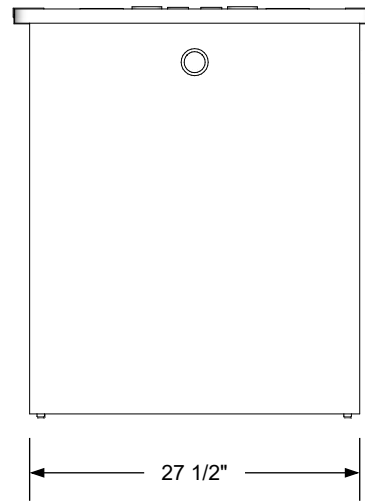
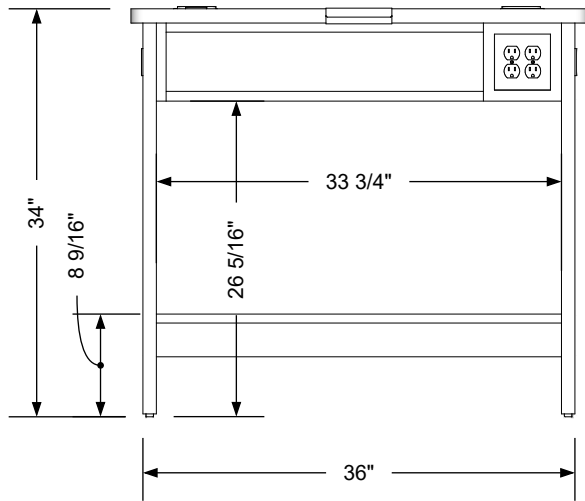

### Additional Information

Assembly required - yes  
 Electrical required - yes  
 Plumbing required - no  
 Wall blocking required - no  
 COM yardage/laminate usage - 70 sf  
 Laminated support legs + 1/4" h glides  
 Other (specify) - n/a  
 Other (specify) - n/a

### Specification Drawing

This **Specification Drawing** is intended for communicating the basic description, function, appearance, dimensions, features, and installation of an item as manufactured by Collins Manufacturing Company. Because this drawing does not contain project specific information such as quantities, finishes, or options, it is not an approval drawing and does not require a signature. This drawing remains the property of Collins Manufacturing Company and must not be used against the interests of Collins Manufacturing Company.

### Product Information

<b>collins</b>		Collins Manufacturing 2000 Bowser Road Cookeville, TN 38506	
Name: Double-Sided Mannequin Desk/Workstation - 36			
Size: NTS	Part Number: 2460-36	Drawn By: Eng	
Prepared Date: 6/15/20	Revision Date: Date	Revision Number: Rev #	Sheet: 1 of 2

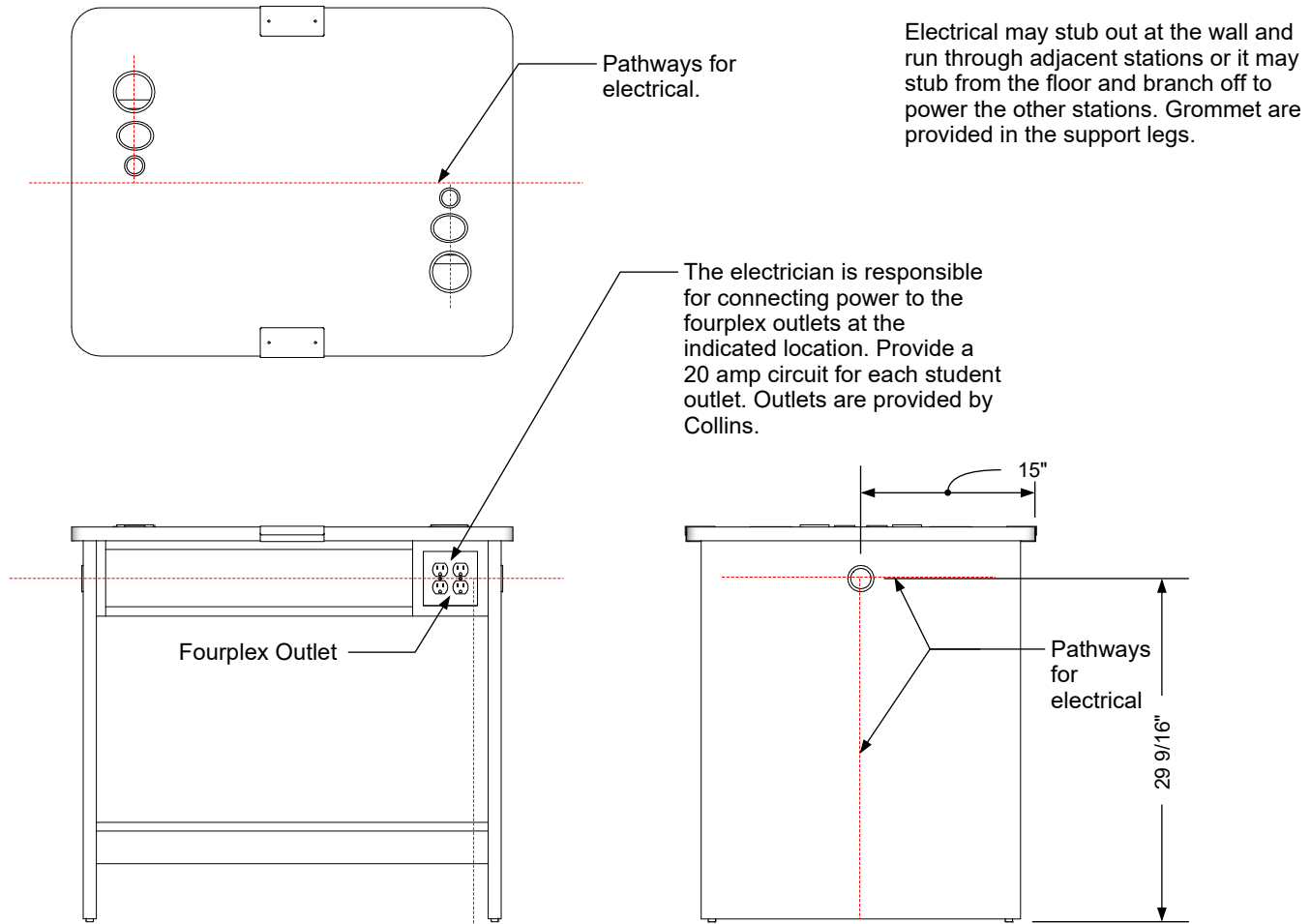

**Electrical stub out detail**

**Additional Information**

Assembly required - yes  
 Electrical required - yes  
 Plumbing required - no  
 Wall blocking required - no  
 COM yardage/laminate usage - 70 sf  
 Laminated support legs + 1/4"h glides  
 Other (specify) - n/a  
 Other (specify) - n/a

**Specification Drawing**

This **Specification Drawing** is intended for communicating the basic description, function, appearance, dimensions, features, and installation of an item as manufactured by Collins Manufacturing Company. Because this drawing does not contain project specific information such as quantities, finishes, or options, it is not an approval drawing and does not require a signature. This drawing remains the property of Collins Manufacturing Company and must not be used against the interests of Collins Manufacturing Company.

**Product Information**

		Collins Manufacturing 2000 Bowser Road Cookeville, TN 38506	
		Name: <b>Double-Sided Mannequin Desk/Workstation - 36</b>	
Size:	Part Number:	Drawn By:	
NTS	2460-36	Eng	
Prepared Date:	Revision Date:	Revision Number:	Sheet:
6/15/20	Date	Rev #	2 of 2