



DOUBLE SIDED MANNEQUIN COMBO DESK FOR FOUR STUDENTS

SKU:2460-72

This salon workstation is the perfect all-in-one solution to create, style and teach from within your school. Features double sided shelving to accommodate four students.

Includes a mannequin holder, built in tool holders for easy access to all of your products, convenient electrical outlets so you can power up your tools, and shelving for storage.

TECHNICAL INFORMATION

- 72"W x 30"D x 34"H
- Includes same feature as single unit
- Available in 72" or 80" lengths

SHIPPING INFORMATION

Item generally ships via Freight(Truck) service

- Weight: 355 lbs
- Dimensions: 96"L x 36"W x 42"H

WARRANTY

3 Years:

- Ball-Bearing Drawer Slides
- Cabinet hinges

1 Year:

- All remaining components, unless noted otherwise, are guaranteed for a period of one year from the date of purchase.



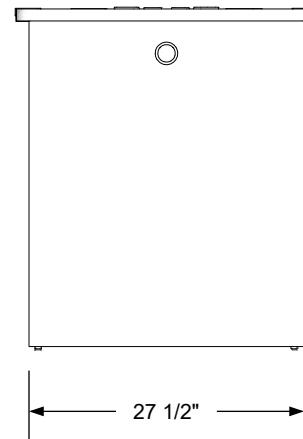
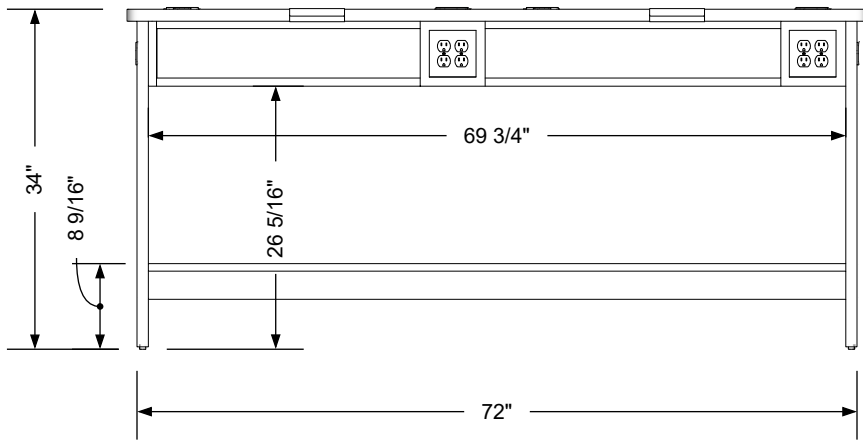
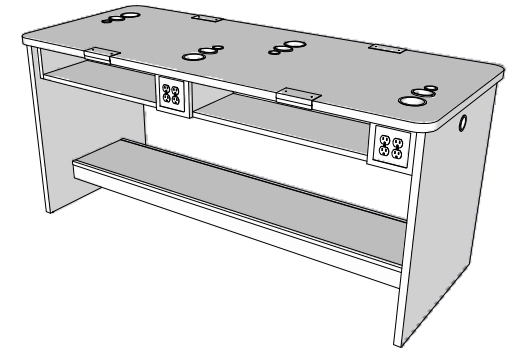
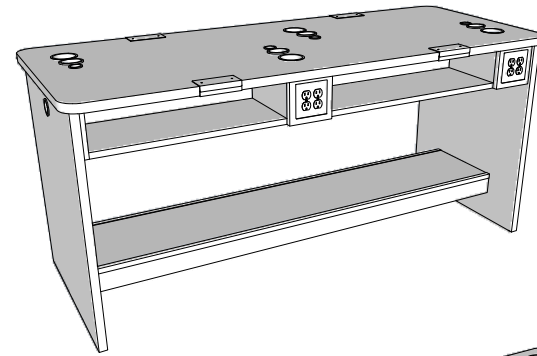
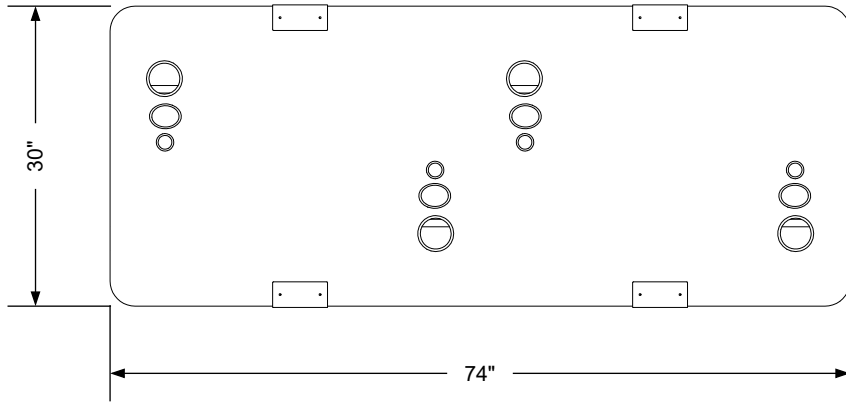

Additional Information

Assembly required - yes
 Electrical required - yes
 Plumbing required - no
 Wall blocking required - no
 COM yardage/laminate usage - 112 sf
 Laminated support legs + 1/4" h glides
 Other (specify) - n/a
 Other (specify) - n/a

Specification Drawing

This **Specification Drawing** is intended for communicating the basic description, function, appearance, dimensions, features, and installation of an item as manufactured by Collins Manufacturing Company. Because this drawing does not contain project specific information such as quantities, finishes, or options, it is not an approval drawing and does not require a signature. This drawing remains the property of Collins Manufacturing Company and must not be used against the interests of Collins Manufacturing Company.

Product Information

		Collins Manufacturing 2000 Bowser Road Cookeville, TN 38506	
Name: Double-Sided Mannequin Desk/Workstation - 72			
Size:	Part Number:	Drawn By:	
NTS	2460-72	Eng	
Prepared Date:	Revision Date:	Revision Number:	Sheet:
6/23/20	Date	Rev #	1 of 2

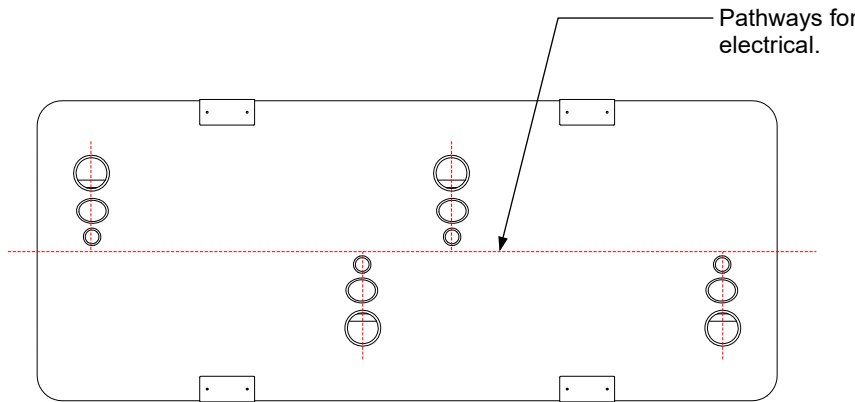

Electrical may stub out at the wall and run through adjacent stations or it may stub from the floor and branch off to power the other stations. Grommet are provided in the support legs.

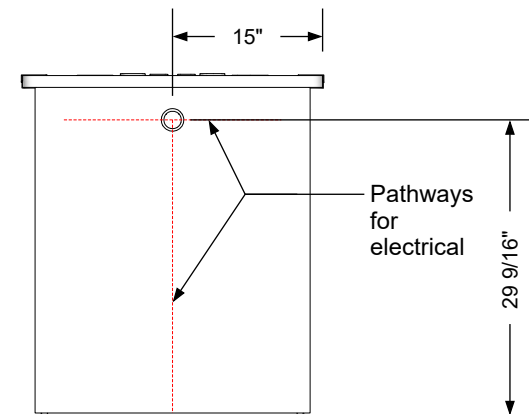
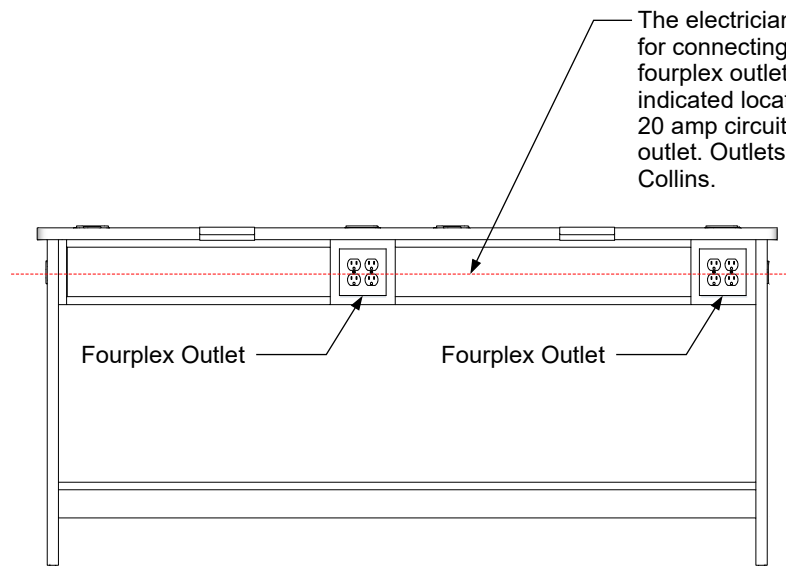

Electrical stub out detail

Additional Information

Assembly required - yes
 Electrical required - yes
 Plumbing required - no
 Wall blocking required - no
 COM yardage/laminate usage - 112 sf
 Laminated support legs + 1/4"h glides
 Other (specify) - n/a
 Other (specify) - n/a

Specification Drawing

This **Specification Drawing** is intended for communicating the basic description, function, appearance, dimensions, features, and installation of an item as manufactured by Collins Manufacturing Company. Because this drawing does not contain project specific information such as quantities, finishes, or options, it is not an approval drawing and does not require a signature. This drawing remains the property of Collins Manufacturing Company and must not be used against the interests of Collins Manufacturing Company.

Product Information

collins		Collins Manufacturing 2000 Bowser Road Cookeville, TN 38506	
Name: Double-Sided Mannequin Desk/Workstation - 72			
Size: NTS	Part Number: 2460-72	Drawn By: Eng	
Prepared Date: 6/23/20	Revision Date: Date	Revision Number: Rev #	Sheet: 2 of 2