



## PORTABLE MANNEQUIN WORKSTATION FOR TWO STUDENTS

SKU:2464-72



This Mannequin Workstation is the perfect addition to any salon, training school or university. The entire unit is designed for mannequins and is made with heavy-duty locking casters for easy movement and can be set up quickly in any location.

Double sided to accommodate two students, this unit has plenty of storage space and built in tool holders along with shelves to hold your various chemicals and supplies.

### TECHNICAL INFORMATION

---

- 72"W x 24"D x 34"H
- Includes overhanging work surface for mannequin head attachment
- Rigid steel frame
- Leg support
- Two curling iron holders
- Two flat iron holders
- Two blow dryer holders
- Interior storage shelf for student kit storage
- Lockable heavy/duty casters

### SHIPPING INFORMATION

---

Item generally ships via Freight(Truck) service

- Weight: 400 lbs
- Dimensions: 84"L x 32"W x 42"H

### WARRANTY

---

#### 3 Years:

- Ball-Bearing Drawer Slides
- Cabinet hinges

#### 1 Year:

- All remaining components, unless noted otherwise, are guaranteed for a period of one year from the date of purchase.

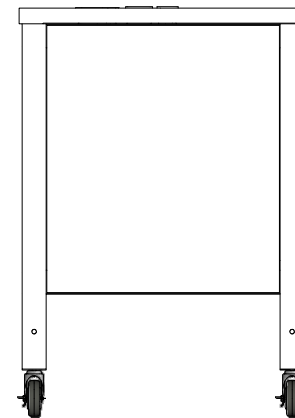
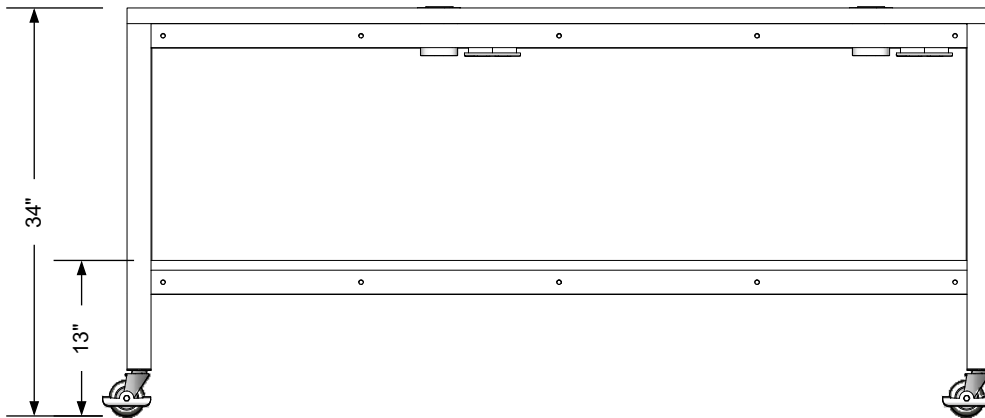
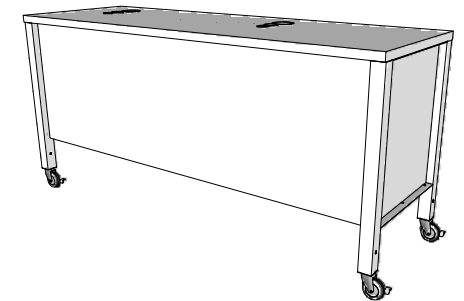
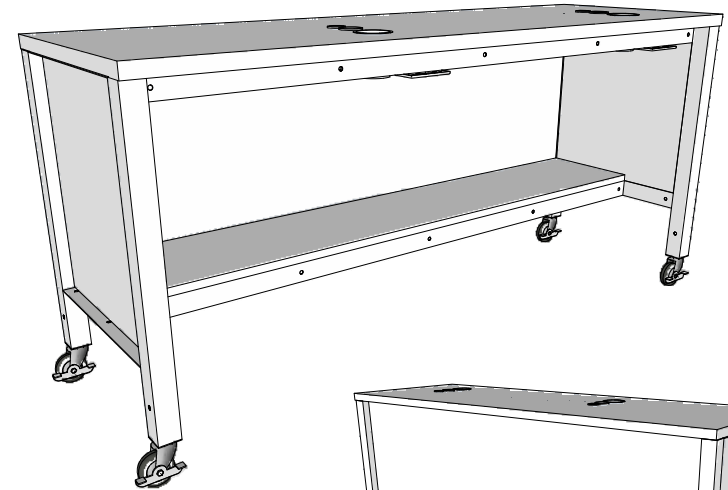
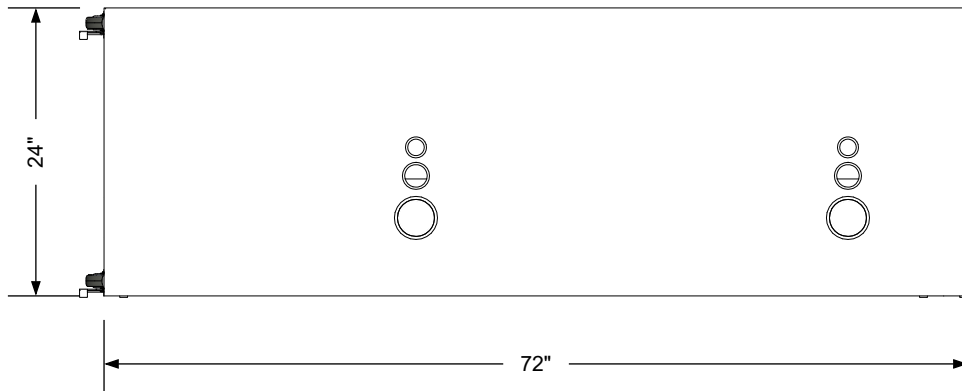

### Additional Information

Assembly required - no  
 Electrical required - yes  
 Plumbing required - no  
 Wall blocking required - no  
 COM yardage/laminate usage - 60 sf  
 Stainless steel legs with locking casters  
 Other (specify) - n/a  
 Other (specify) - n/a

### Specification Drawing

This **Specification Drawing** is intended for communicating the basic description, function, appearance, dimensions, features, and installation of an item as manufactured by Collins Manufacturing Company. Because this drawing does not contain project specific information such as quantities, finishes, or options, it is not an approval drawing and does not require a signature. This drawing remains the property of Collins Manufacturing Company and must not be used against the interests of Collins Manufacturing Company.

### Product Information

		Collins Manufacturing 2000 Bowser Road Cookeville, TN 38506	
Name: Portable Mannequin Workstation for Two Students - 72			
Size:	Part Number:	Drawn By:	
NTS	2464-72	Eng	
Prepared Date:	Revision Date:	Revision Number:	Sheet:
6/27/20	Date	Rev #	1 of 2

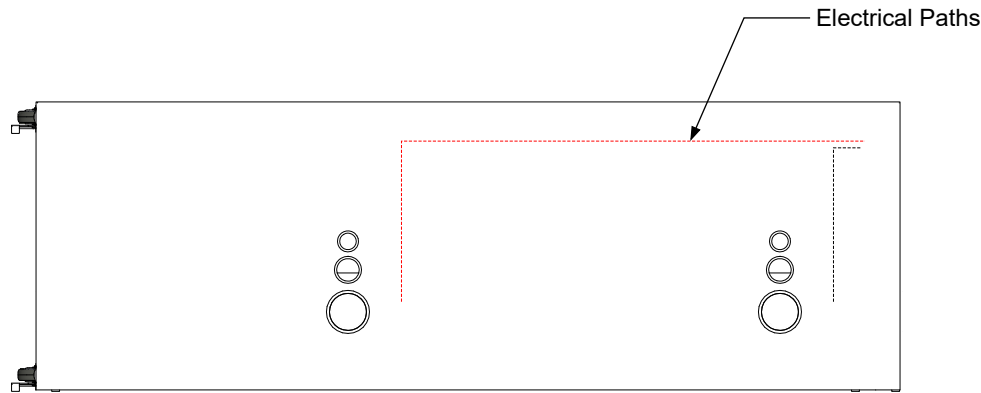

Each station is shipped with (2) loose, 8' long power cords. The electrician is responsible for running the cords up to the outlets, connecting to the fourplex outlets, and providing a 20 amp, switched outlet for each power cord to plug into.

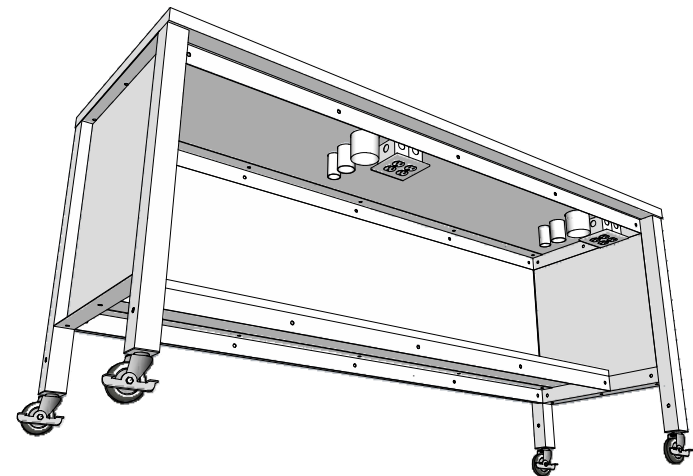
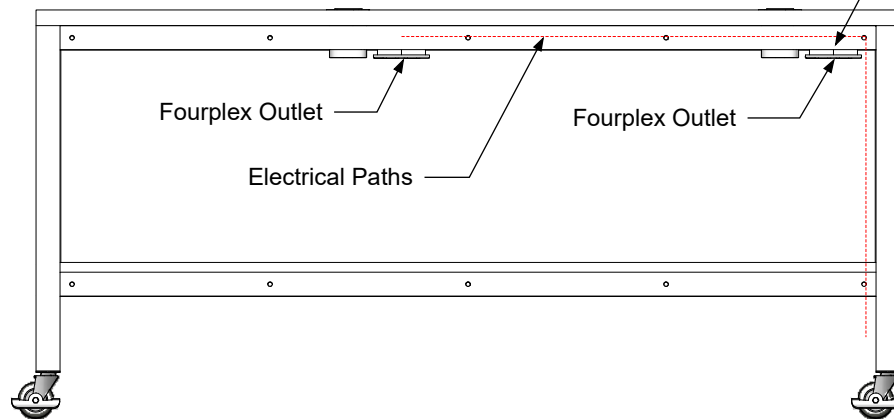

### Electrical stub out detail

#### Additional Information

Assembly required - no  
 Electrical required - yes  
 Plumbing required - no  
 Wall blocking required - no  
 COM yardage/laminate usage - 60 sf  
 Stainless steel legs with locking casters  
 Other (specify) - n/a  
 Other (specify) - n/a

#### Specification Drawing

This **Specification Drawing** is intended for communicating the basic description, function, appearance, dimensions, features, and installation of an item as manufactured by Collins Manufacturing Company. Because this drawing does not contain project specific information such as quantities, finishes, or options, it is not an approval drawing and does not require a signature. This drawing remains the property of Collins Manufacturing Company and must not be used against the interests of Collins Manufacturing Company.

#### Product Information

<b>collins</b>		Collins Manufacturing 2000 Bowser Road Cookeville, TN 38506	
Name: Portable Mannequin Workstation for Two Students - 72			
Size: NTS	Part Number: 2464-72	Drawn By: Eng	
Prepared Date: 6/27/20	Revision Date: Date	Revision Number: Rev #	Sheet: 2 of 2