



## VERSA CART

SKU:2470-20

Versa Cart is a multi-use cart that doubles as a podium and has enough storage space for plenty of tools. It is easy to move around, with casters for mobility, and has a locking storage cabinet to keep your larger tools safe!

### TECHNICAL INFORMATION

- 20"W x 21"D x 40"H
  - Articulating podium-style top w/ mannequin clamp
  - Locking casters
  - Breadboard
  - Full-extension drawer
  - Six-outlet power strip
  - Additional drawer
- 6 removable stainless steel tool panels:
- Styling, Barber, Color, Marcel styling, Flat, and Stainless steel bin

### SHIPPING INFORMATION

Item generally ships via Freight(Truck) service

- Weight: 165 lbs
- Dimensions: 32"L x 30"W x 48"H

### WARRANTY

#### 3 Years:

- Ball-Bearing Drawer Slides
- Cabinet hinges

#### 1 Year:

- All remaining components, unless noted otherwise, are guaranteed for a period of one year from the date of purchase.



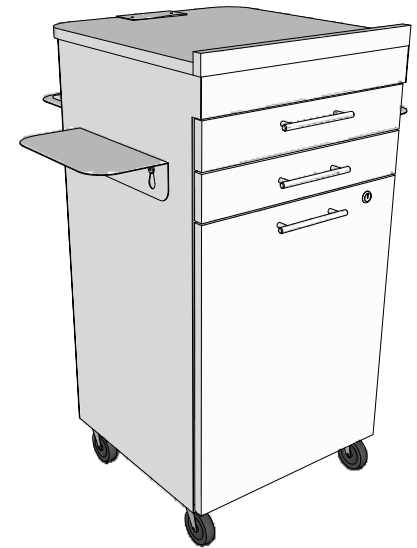
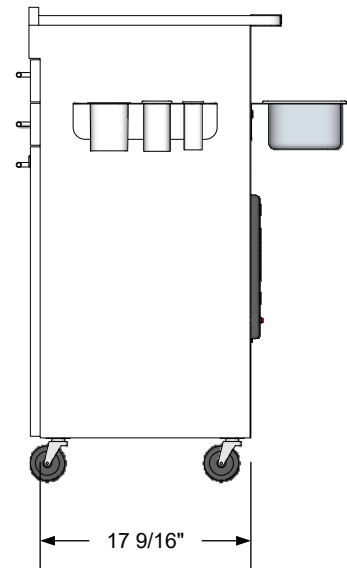
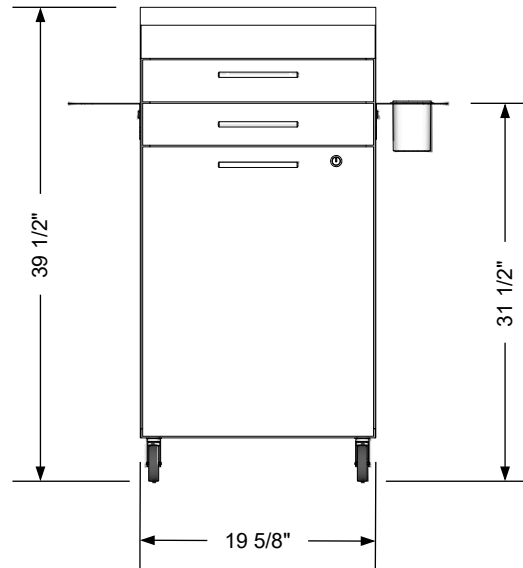
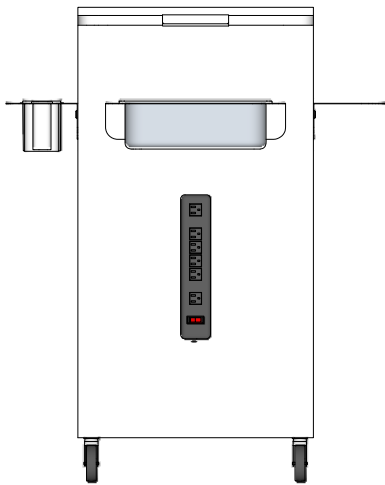
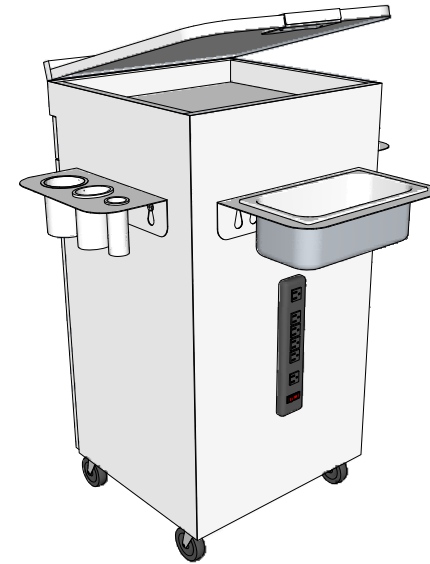
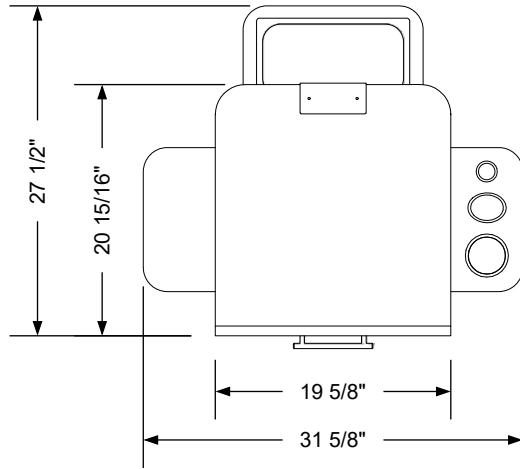

### Additional Information

Assembly required - yes  
 Electrical required - yes  
 Plumbing required - no  
 Wall blocking required - no  
 COM yardage/laminate usage - 36 sf  
 4" h laminated plywood toe + 1/4" h glides  
 Other (specify) - n/a  
 Other (specify) - n/a

### Specification Drawing

This **Specification Drawing** is intended for communicating the basic description, function, appearance, dimensions, features, and installation of an item as manufactured by Collins Manufacturing Company. Because this drawing does not contain project specific information such as quantities, finishes, or options, it is not an approval drawing and does not require a signature. This drawing remains the property of Collins Manufacturing Company and must not be used against the interests of Collins Manufacturing Company.

### Product Information

		Collins Manufacturing 2000 Bowser Road Cookeville, TN 38506	
		Name: Versa Cart	
Size: NTS	Part Number: 2470-20	Drawn By: Eng	
Prepared Date: 7/2/20	Revision Date: Date	Revision Number: Rev #	Sheet: 1 of 2

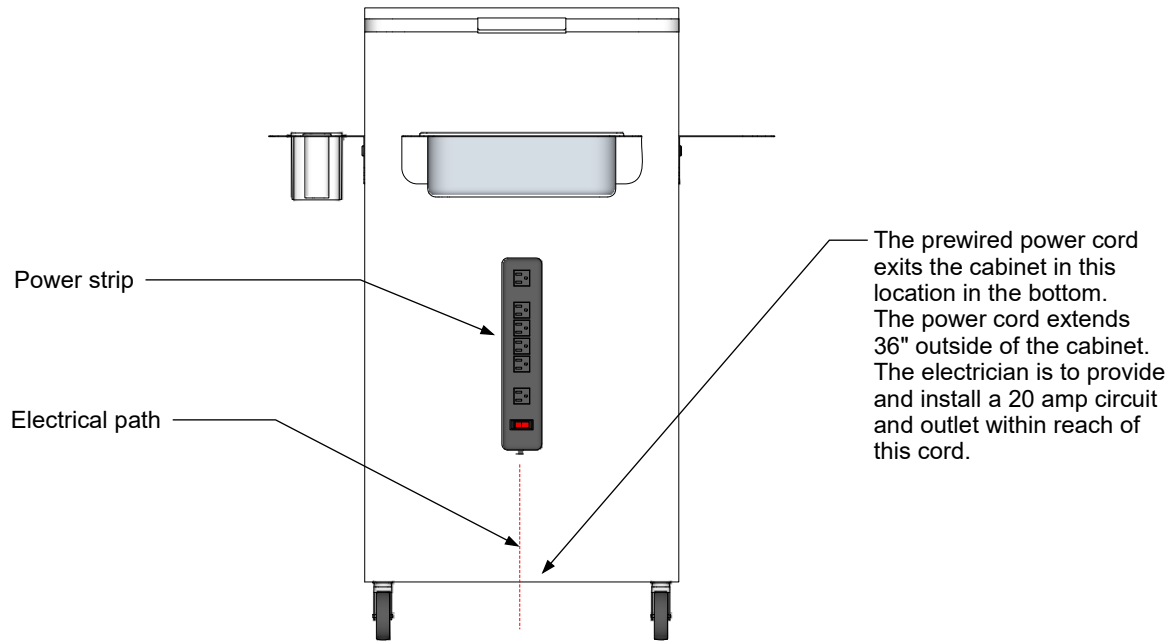

**Electrical stub out detail**

**Additional Information**

Assembly required - yes  
 Electrical required - yes  
 Plumbing required - no  
 Wall blocking required - no  
 COM yardage/laminate usage - 36 sf  
 4"h laminated plywood toe + 1/4"h glides  
 Other (specify) - n/a  
 Other (specify) - n/a

**Specification Drawing**

This **Specification Drawing** is intended for communicating the basic description, function, appearance, dimensions, features, and installation of an item as manufactured by Collins Manufacturing Company. Because this drawing does not contain project specific information such as quantities, finishes, or options, it is not an approval drawing and does not require a signature. This drawing remains the property of Collins Manufacturing Company and must not be used against the interests of Collins Manufacturing Company.

**Product Information**

		Collins Manufacturing 2000 Bowser Road Cookeville, TN 38506	
Name: <b>Versa Cart</b>			
Size: <b>NTS</b>	Part Number: <b>2470-20</b>	Drawn By: <b>Eng</b>	
Prepared Date: <b>7/2/20</b>	Revision Date: <b>Date</b>	Revision Number: <b>Rev #</b>	Sheet: <b>2 of 2</b>