



## BREAKROOM CABINETRY

SKU:2684-96

The Breakroom Cabinetry perfect for a school setting.

### TECHNICAL INFORMATION

---

- 96"W x 25"D x 90"H
- Five drawers
- Eight cabinets
- Waste cabinet
- Open spot for microwave
- Double sided sink
- This is a basic example but can be customized to fit your space

### SHIPPING INFORMATION

---

Item generally ships via Freight(Truck) service

- Weight: 715 lbs
- Dimensions: 3 pallets

### WARRANTY

---

#### 7.5 Years:

- Models 3500, 4500, 5550 Foot Operated Hydraulic Pumps

#### 5 years:

- Collins Comfort Zone anti-fatigue mats
- Collins all purpose and shampoo chair back reclining mechanisms
- Models 3250, 4250, 5250 Foot Operated Hydraulic Pumps

#### 3 Years:

- BKB Electric Base

#### 1 year:

- All remaining components, unless otherwise noted



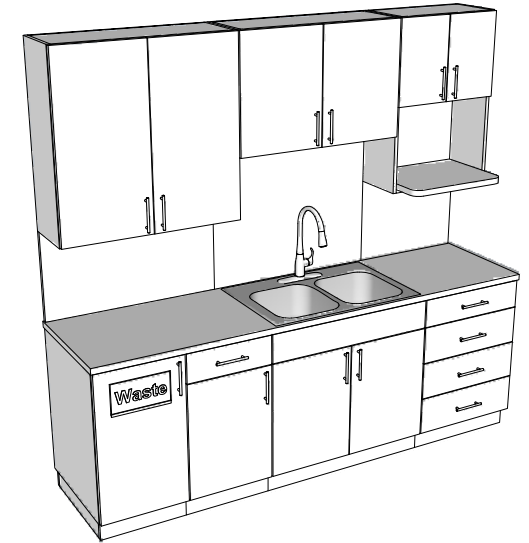
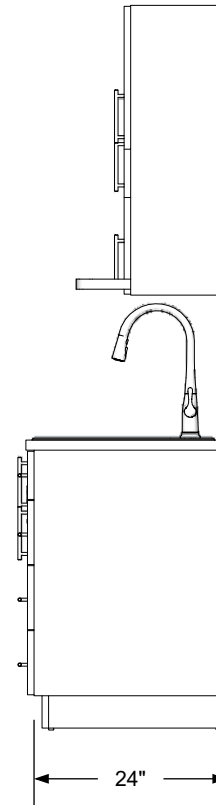
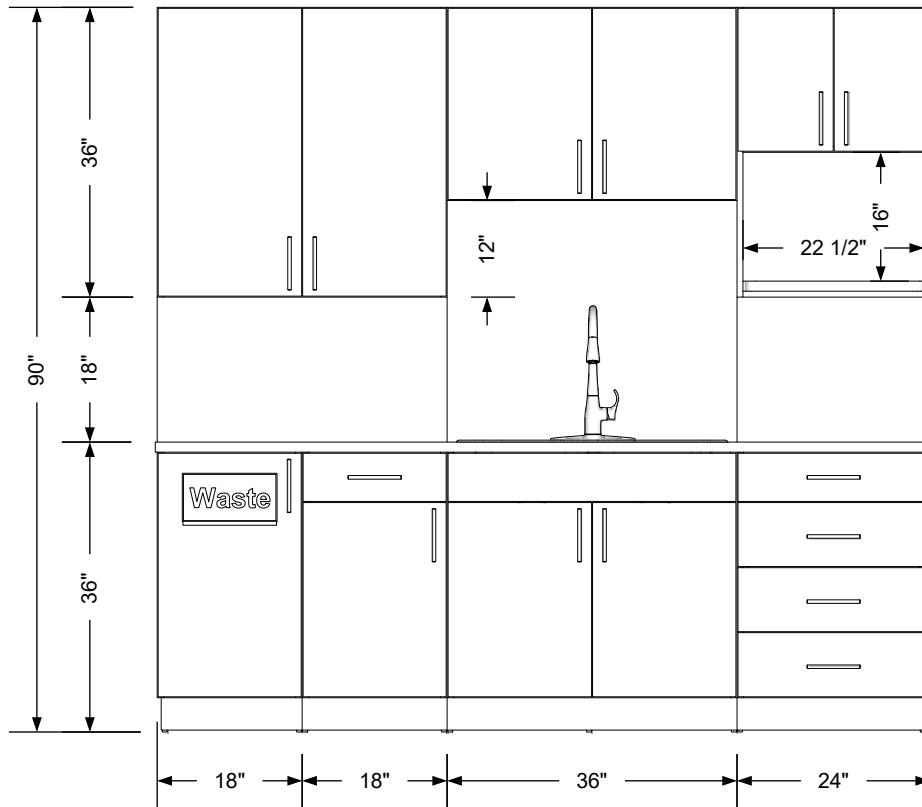
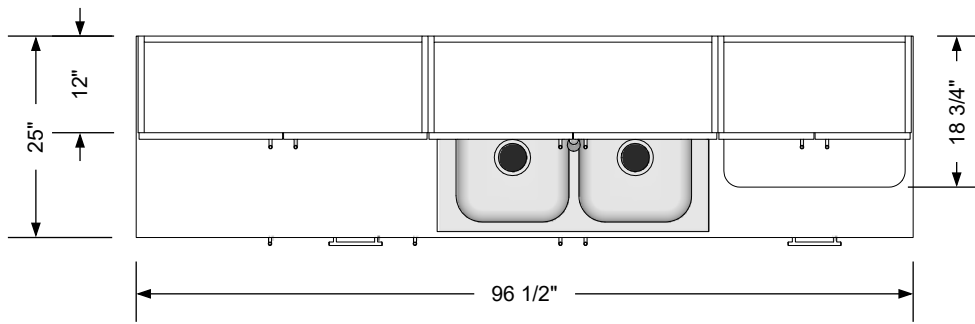

**Additional Information**

Assembly required - yes  
 Electrical required - yes  
 Plumbing required - yes  
 Wall blocking required - yes  
 COM yardage/laminate usage - 178 sf  
 4" h laminated plywood toe + 1/4" h glides  
 Other (specify) - n/a  
 Other (specify) - n/a

**Specification Drawing**

This **Specification Drawing** is intended for communicating the basic description, function, appearance, dimensions, features, and installation of an item as manufactured by Collins Manufacturing Company. Because this drawing does not contain project specific information such as quantities, finishes, or options, it is not an approval drawing and does not require a signature. This drawing remains the property of Collins Manufacturing Company and must not be used against the interests of Collins Manufacturing Company.

**Product Information**

		Collins Manufacturing 2000 Bowser Road Cookeville, TN 38506	
Name: <b>Breakroom Cabinetry</b>			
Size: <b>NTS</b>	Part Number: <b>2684-96</b>	Drawn By: <b>Eng</b>	
Prepared Date: <b>7/7/20</b>	Revision Date: <b>Date</b>	Revision Number: <b>Rev #</b>	Sheet: <b>1 of 3</b>

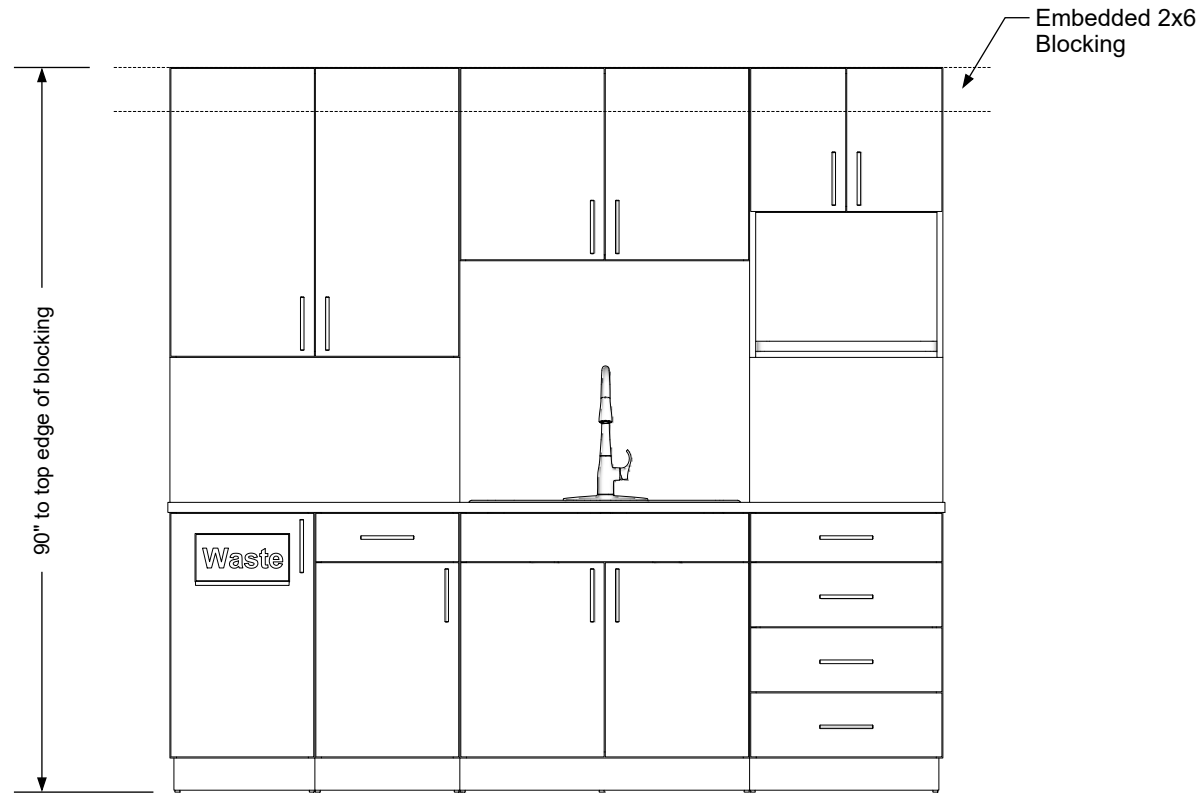

**Wall blocking detail**

**Additional Information**

Assembly required - yes  
 Electrical required - yes  
 Plumbing required - yes  
 Wall blocking required - yes  
 COM yardage/laminate usage - 178 sf  
 4" h laminated plywood toe + 1/4" h glides  
 Other (specify) - n/a  
 Other (specify) - n/a

**Specification Drawing**

This **Specification Drawing** is intended for communicating the basic description, function, appearance, dimensions, features, and installation of an item as manufactured by Collins Manufacturing Company. Because this drawing does not contain project specific information such as quantities, finishes, or options, it is not an approval drawing and does not require a signature. This drawing remains the property of Collins Manufacturing Company and must not be used against the interests of Collins Manufacturing Company.

**Product Information**

		Collins Manufacturing 2000 Bowser Road Cookeville, TN 38506	
Name: Breakroom Cabinetry			
Size: NTS	Part Number: 2684-96	Drawn By: Eng	
Prepared Date: 7/7/20	Revision Date: Date	Revision Number: Rev #	Sheet: 2 of 3

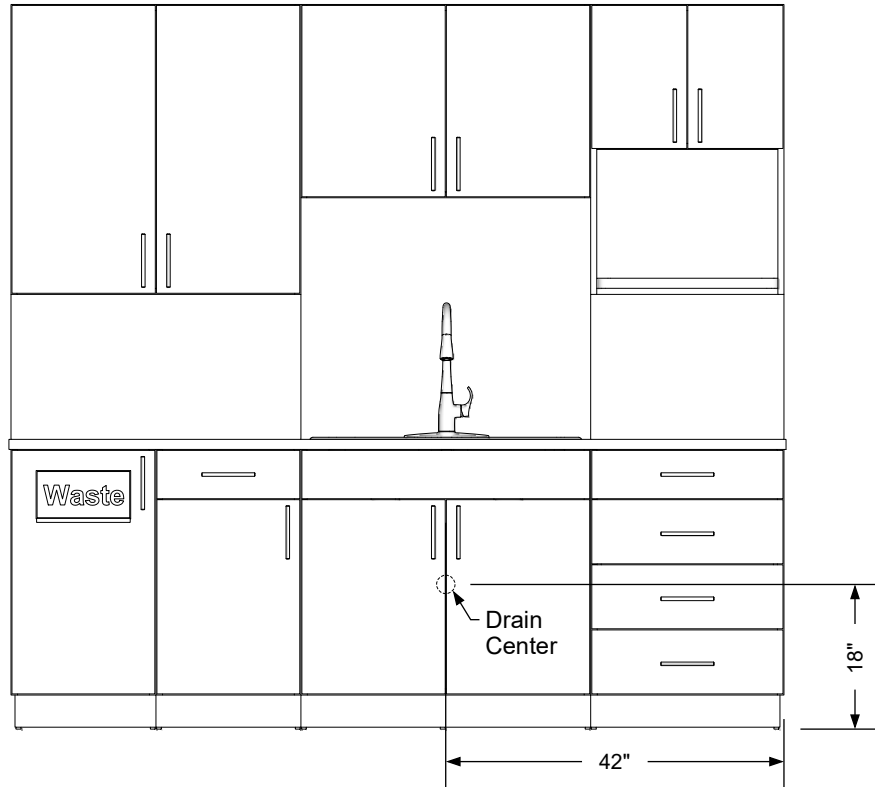

**Plumbing stub out detail**

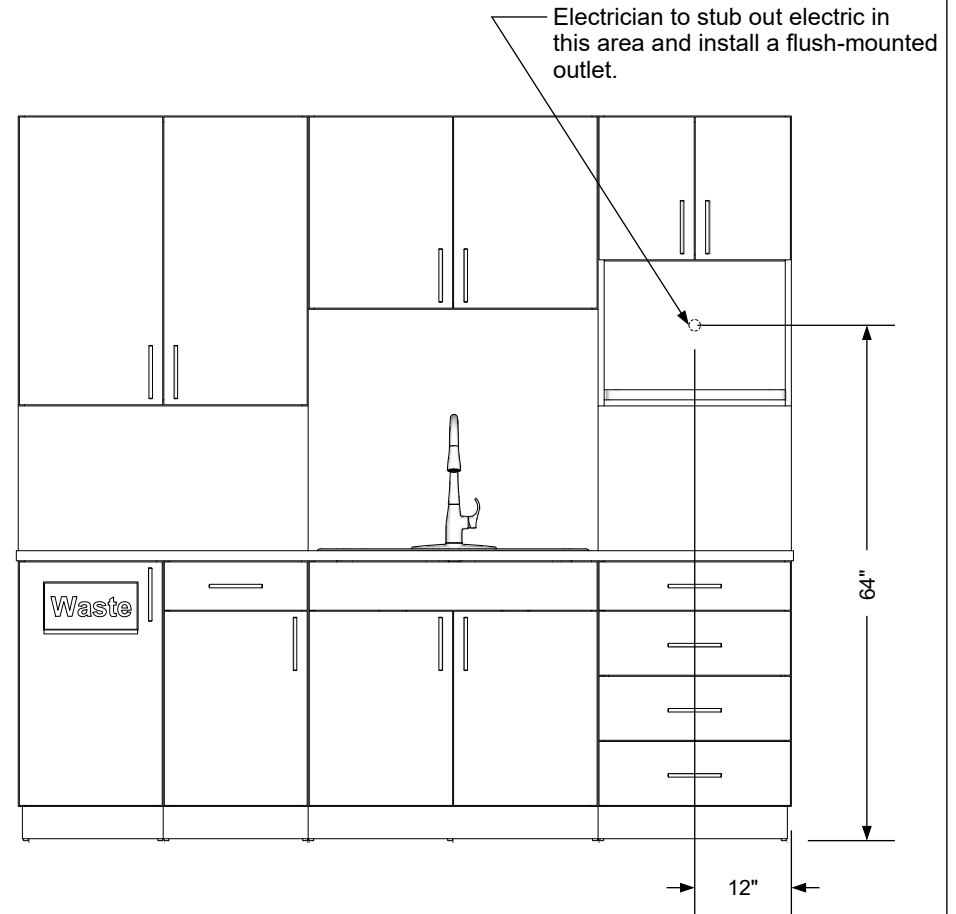

**Electrical stub out detail**

**Additional Information**

Assembly required - yes  
 Electrical required - yes  
 Plumbing required - yes  
 Wall blocking required - yes  
 COM yardage/laminate usage - 178 sf  
 4"h laminated plywood toe + 1/4"h glides  
 Other (specify) - n/a  
 Other (specify) - n/a

**Specification Drawing**

This **Specification Drawing** is intended for communicating the basic description, function, appearance, dimensions, features, and installation of an item as manufactured by Collins Manufacturing Company. Because this drawing does not contain project specific information such as quantities, finishes, or options, it is not an approval drawing and does not require a signature. This drawing remains the property of Collins Manufacturing Company and must not be used against the interests of Collins Manufacturing Company.

**Product Information**

<b>collins</b>		Collins Manufacturing 2000 Bowser Road Cookeville, TN 38506	
Name: <b>Breakroom Cabinetry</b>			
Size: <b>NTS</b>	Part Number: <b>2684-96</b>	Drawn By: <b>Eng</b>	
Prepared Date: <b>7/7/20</b>	Revision Date: <b>Date</b>	Revision Number: <b>Rev #</b>	Sheet: <b>3 of 3</b>