



## ADA BATHROOM VANITY

SKU:2685-72



Our bathroom vanity with two sinks is a great addition to any bathroom and is ADA compliant. The angled base creates extra room for you to maneuver and the countertop space provides ample storage for all of your items. This bathroom vanity can be used in residential or commercial settings.

### TECHNICAL INFORMATION

---

- 72"W x 25"D x 34"H
- Two sinks
- Counter space

### SHIPPING INFORMATION

---

Item generally ships via Freight(Truck) service

- Weight: 250 lbs
- Dimensions: 84"L x 32"W x 36"H

### WARRANTY

---

#### 3 Years:

- Ball-Bearing Drawer Slides
- Cabinet hinges

#### 1 Year:

- All remaining components, unless noted otherwise, are guaranteed for a period of one year from the date of purchase.

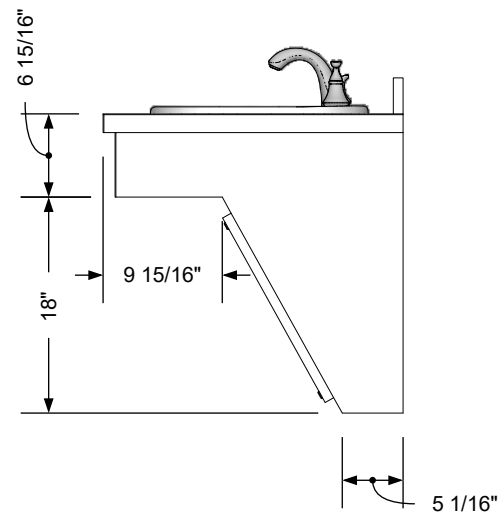
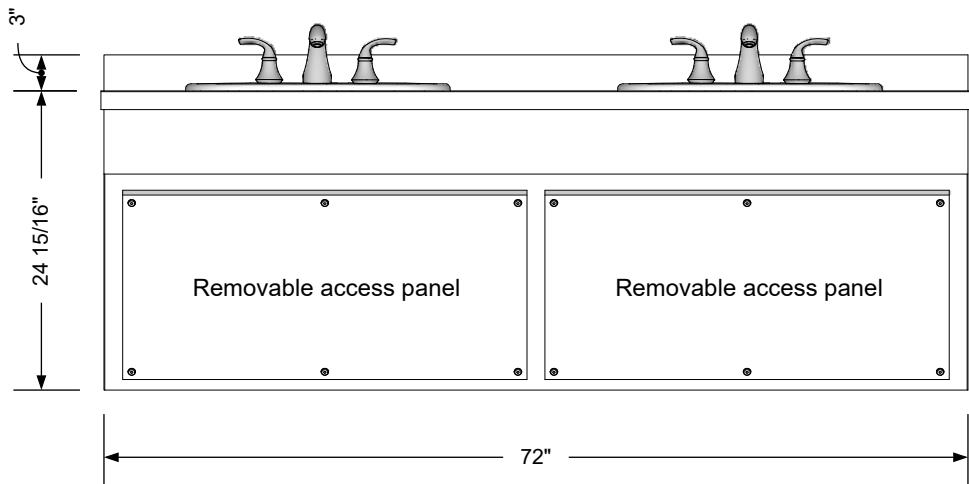
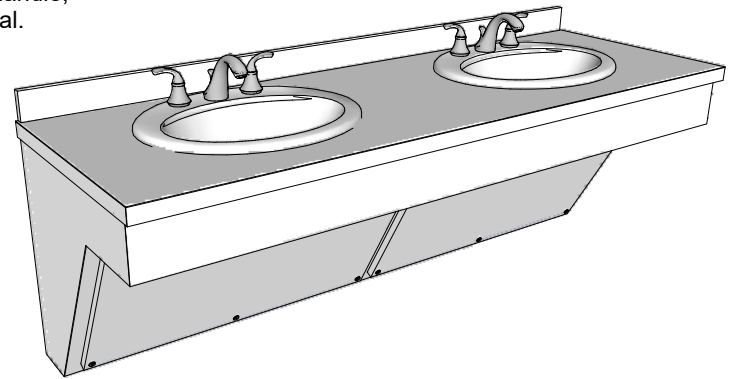
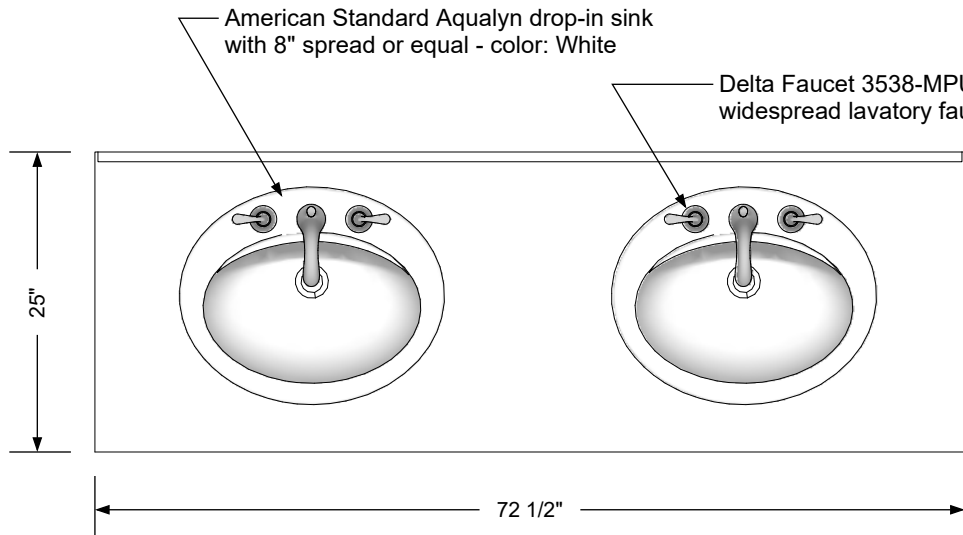

### Additional Information

Assembly required - yes  
 Electrical required - no  
 Plumbing required - yes  
 Wall blocking required - yes  
 COM yardage/laminate usage - 72 sf  
 Other (specify) - n/a  
 Other (specify) - n/a  
 Other (specify) - n/a

### Specification Drawing

This **Specification Drawing** is intended for communicating the basic description, function, appearance, dimensions, features, and installation of an item as manufactured by Collins Manufacturing Company. Because this drawing does not contain project specific information such as quantities, finishes, or options, it is not an approval drawing and does not require a signature. This drawing remains the property of Collins Manufacturing Company and must not be used against the interests of Collins Manufacturing Company.

### Product Information

<b>collins</b>		Collins Manufacturing 2000 Bowser Road Cookeville, TN 38506	
Name: <b>ADA Bathroom Vanity</b>			
Size: <b>NTS</b>	Part Number: <b>2685-72</b>	Drawn By: <b>Eng</b>	
Prepared Date: <b>7/7/20</b>	Revision Date: <b>3/21/23</b>	Revision Number: <b>Rev #1</b>	Sheet: <b>1 of 2</b>

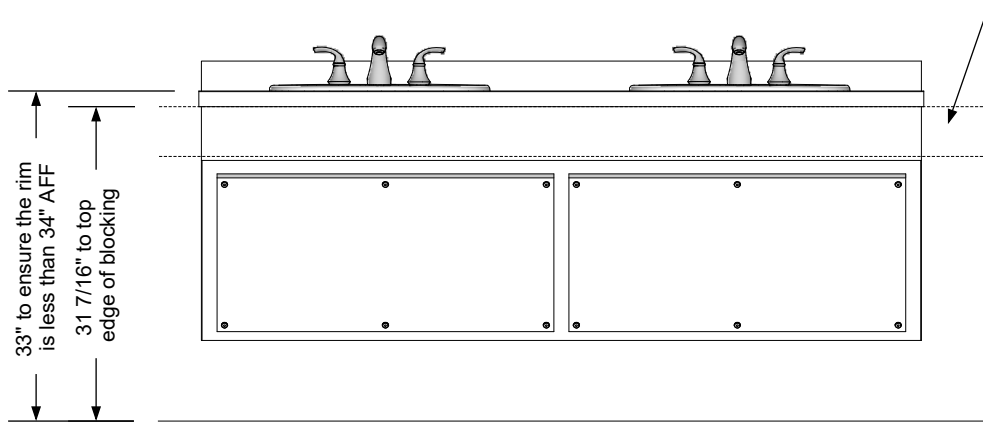

**Wall blocking detail**

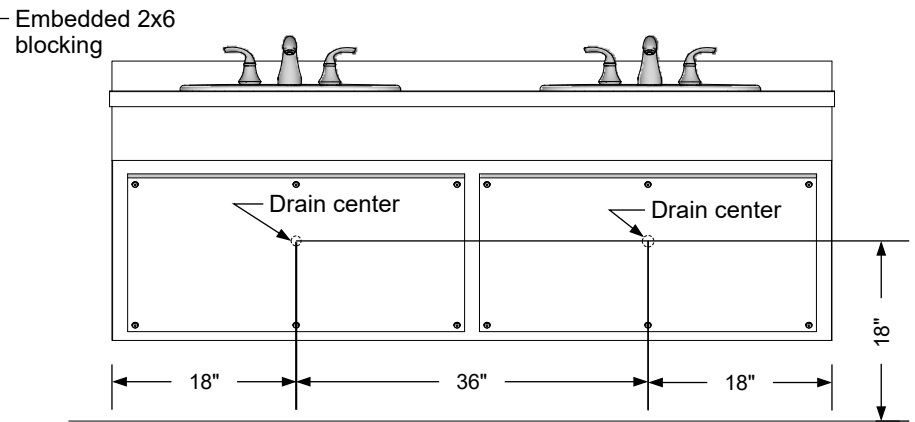

**Plumbing stub out detail**

**Additional Information**

Assembly required - yes  
 Electrical required - no  
 Plumbing required - yes  
 Wall blocking required - yes  
 COM yardage/laminate usage - 72 sf  
 Other (specify) - n/a  
 Other (specify) - n/a  
 Other (specify) - n/a

**Specification Drawing**

This **Specification Drawing** is intended for communicating the basic description, function, appearance, dimensions, features, and installation of an item as manufactured by Collins Manufacturing Company. Because this drawing does not contain project specific information such as quantities, finishes, or options, it is not an approval drawing and does not require a signature. This drawing remains the property of Collins Manufacturing Company and must not be used against the interests of Collins Manufacturing Company.

**Product Information**

		Collins Manufacturing 2000 Bowser Road Cookeville, TN 38506	
Name: ADA Bathroom Vanity			
Size: NTS	Part Number: 2685-72	Drawn By: Eng	
Prepared Date: 7/7/20	Revision Date: 3/21/23	Revision Number: Rev #1	Sheet: 2 of 2