



MAKEUP VANITY

SKU:2690-60

Add a touch of glam to your salon or spa with this professional Makeup Vanity. The hollywood style lights and storage below will help you create the perfect look. Available in a variety of laminate color choices.

TECHNICAL INFORMATION

- Hollywood style mirror light fixtures
- Six drawers
- Four cabinets

SHIPPING INFORMATION

Item generally ships via Freight(Truck) service

- Weight: 450 lbs
- Dimensions: 2 pallets

WARRANTY

3 Years:

- Ball-Bearing Drawer Slides
- Cabinet hinges

1 Year:

- All remaining components, unless noted otherwise, are guaranteed for a period of one year from the date of purchase.



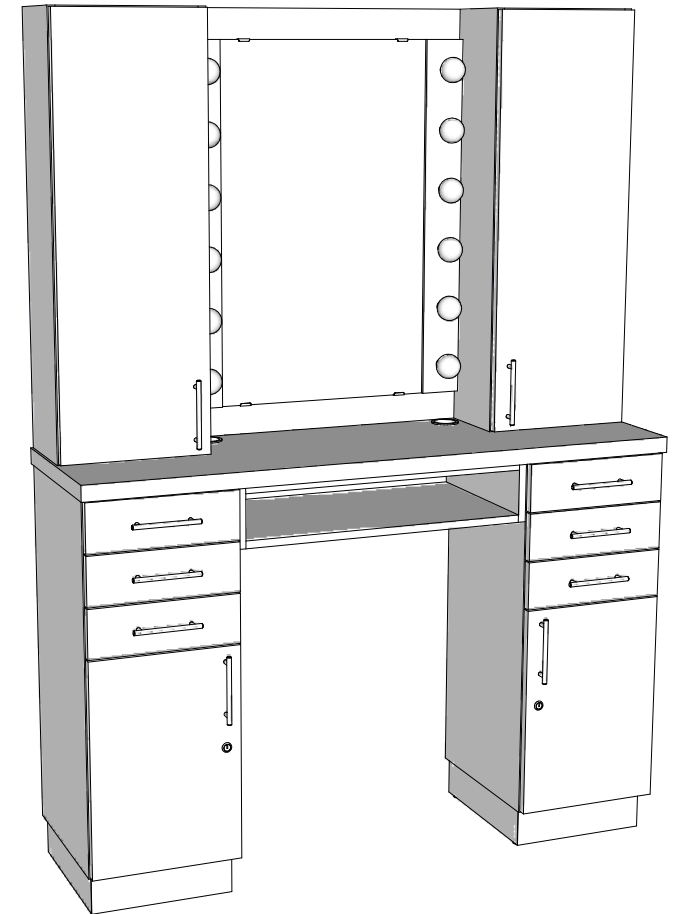
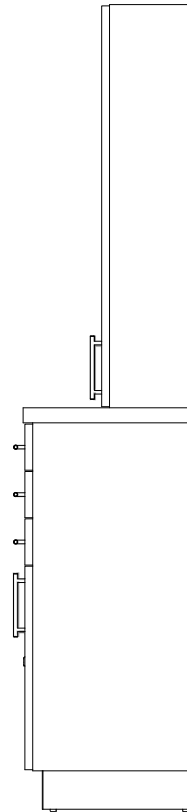
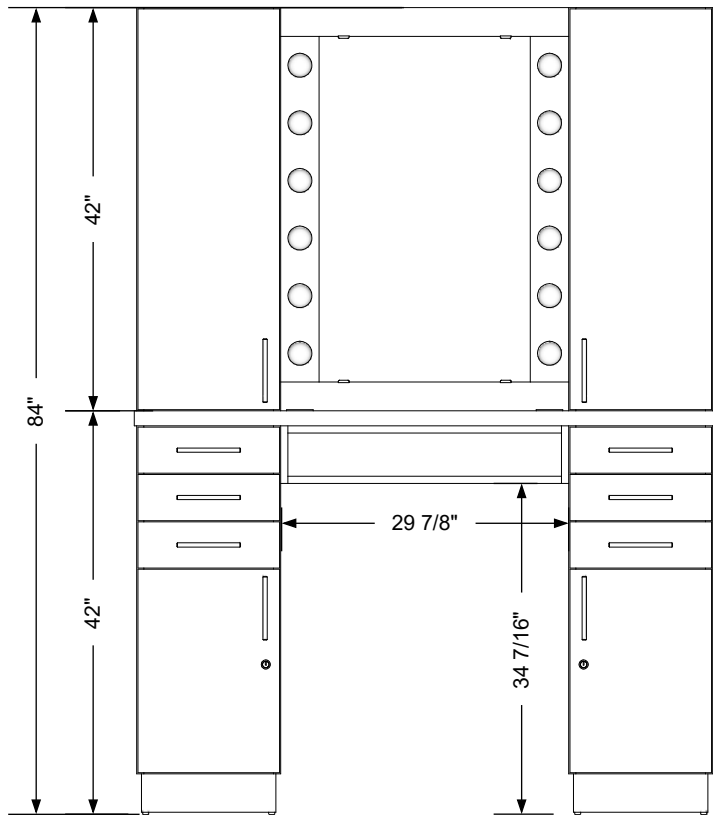
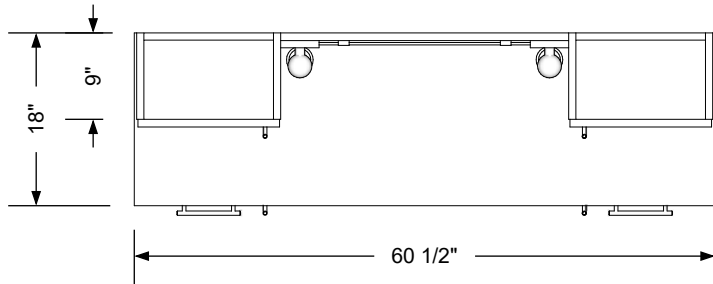

Additional Information

Assembly required - yes
 Electrical required - yes
 Plumbing required - n/a
 Wall blocking required - yes
 COM yardage/laminate usage -
 4" h laminated plywood toe + 1/4" h glides
 Other (specify) - n/a
 Other (specify) - n/a

Specification Drawing

This **Specification Drawing** is intended for communicating the basic description, function, appearance, dimensions, features, and installation of an item as manufactured by Collins Manufacturing Company. Because this drawing does not contain project specific information such as quantities, finishes, or options, it is not an approval drawing and does not require a signature. This drawing remains the property of Collins Manufacturing Company and must not be used against the interests of Collins Manufacturing Company.

Product Information

		Collins Manufacturing 2000 Bowser Road Cookeville, TN 38506	
Name: Makeup Vanity			
Size: NTS	Part Number: 2690-60	Drawn By: Eng	
Prepared Date: 4/17/20	Revision Date: Date	Revision Number: Rev #	Sheet: 1 of 2

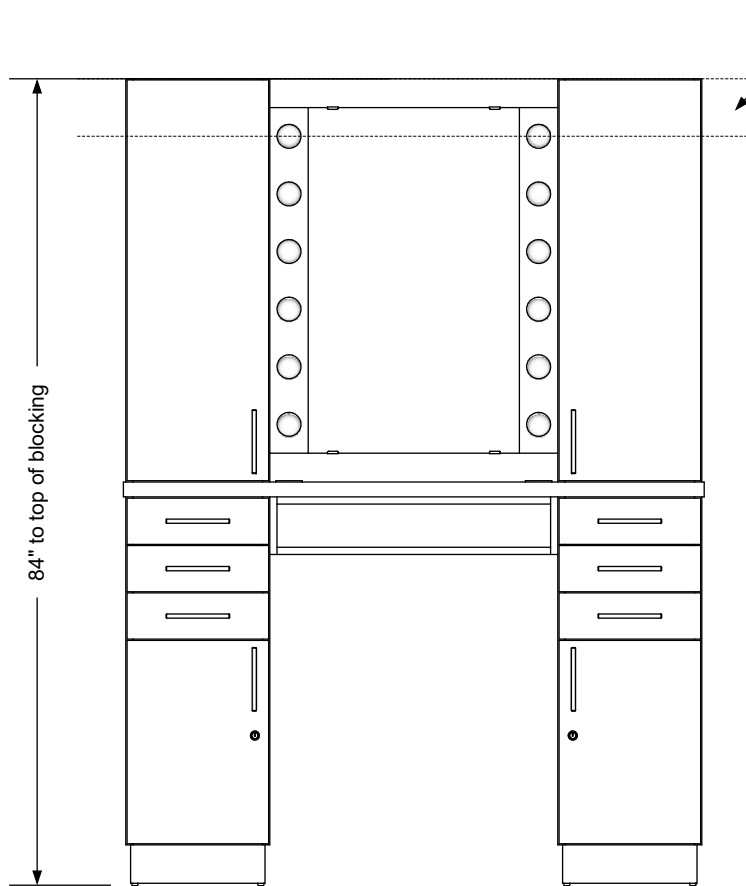

Wall blocking detail

2x6 Embedded wall blocking

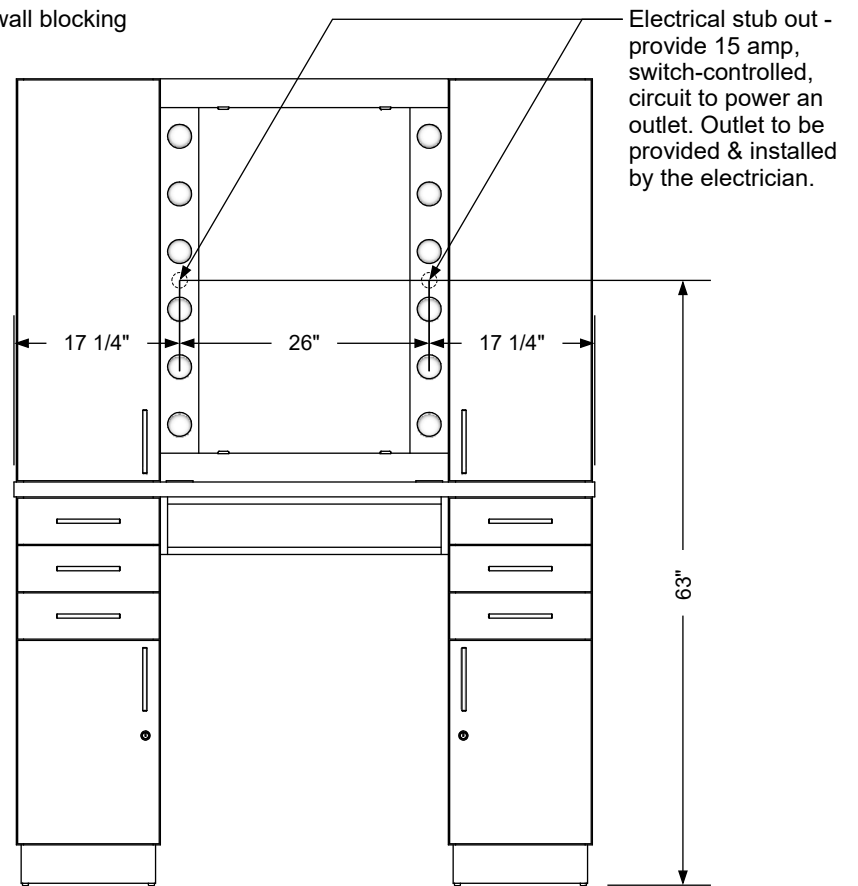

Electrical stub out detail

Additional Information

Assembly required - yes
 Electrical required - yes
 Plumbing required - n/a
 Wall blocking required - yes
 COM yardage/laminate usage -
 4" h laminated plywood toe + 1/4" h glides
 Other (specify) - n/a
 Other (specify) - n/a

Specification Drawing

This **Specification Drawing** is intended for communicating the basic description, function, appearance, dimensions, features, and installation of an item as manufactured by Collins Manufacturing Company. Because this drawing does not contain project specific information such as quantities, finishes, or options, it is not an approval drawing and does not require a signature. This drawing remains the property of Collins Manufacturing Company and must not be used against the interests of Collins Manufacturing Company.

Product Information

		Collins Manufacturing 2000 Bowser Road Cookeville, TN 38506	
Name: Makeup Vanity			
Size: NTS	Part Number: 2690-60	Drawn By: Eng	
Prepared Date: 4/17/20	Revision Date: Date	Revision Number: Rev #	Sheet: 2 of 2