



# VEECO TRANQUILITY ELECTRIC SHAMPOO UNIT

SKU:2850



Elegant lines and smooth transitions make the Veeco Tranquility Shampoo Unit a great solution to enhance the shampooing experience in your salon. The motorized footrest (**with fast 7-second lift time**) and tilting shampoo bowl provide excellent comfort for most guests. Lift up seat provides for easy access to plumbing connections. Black is normally ready ship. Can order 2850.C in vinyl of your choosing, normal lead times apply.

## TECHNICAL INFORMATION

- Width between the arms 23"
- Width outside the arms 29"
- Height to the top of the back 29"
- Height to top of seat 19"
- Depth of seat 18"
- Overall depth 48"
- Overall depth w/ footrest & chair completely extended 64"
- UPC listed Shampoo bowl and components
- 2Amps - Power requirement that plugs into standard 120V receptacle

## SHIPPING INFORMATION

- Weight 250 lbs
- Dimensions: 32"W x 48"D x 42"H
- Bowl weight 72 lbs
- Bowl dimensions 26"L x 26"W x 25"H

## WARRANTY

### 3 Years:

- Ball-Bearing Drawer Slides
- Cabinet hinges

### 1 Year:

- All remaining components, unless noted otherwise, are guaranteed for a period of one year from the date of purchase.



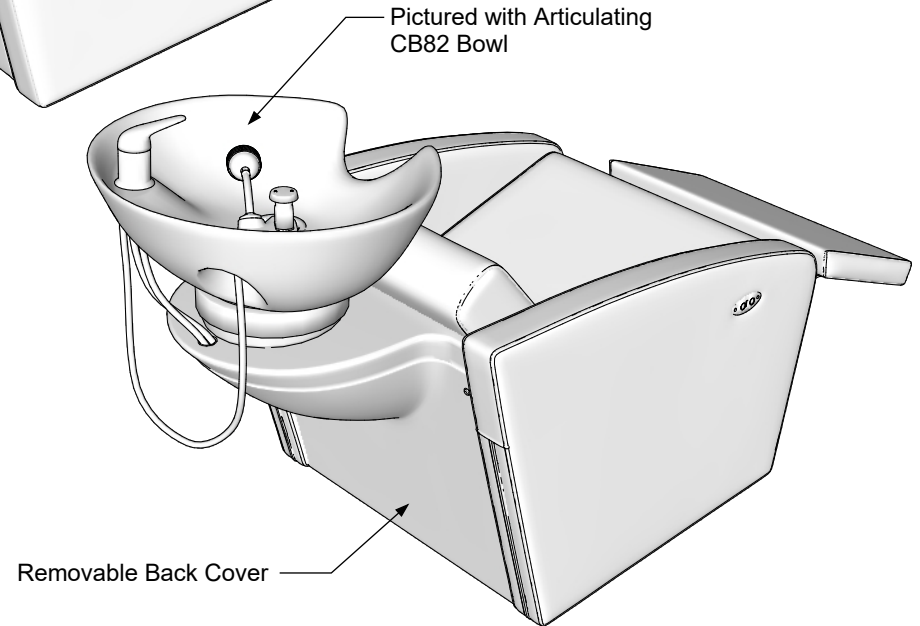
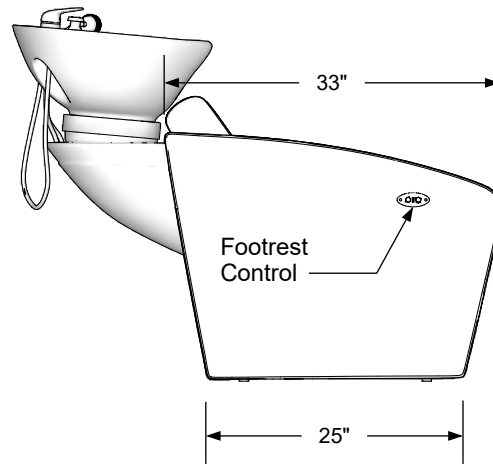
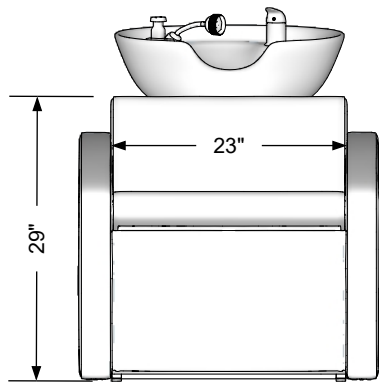
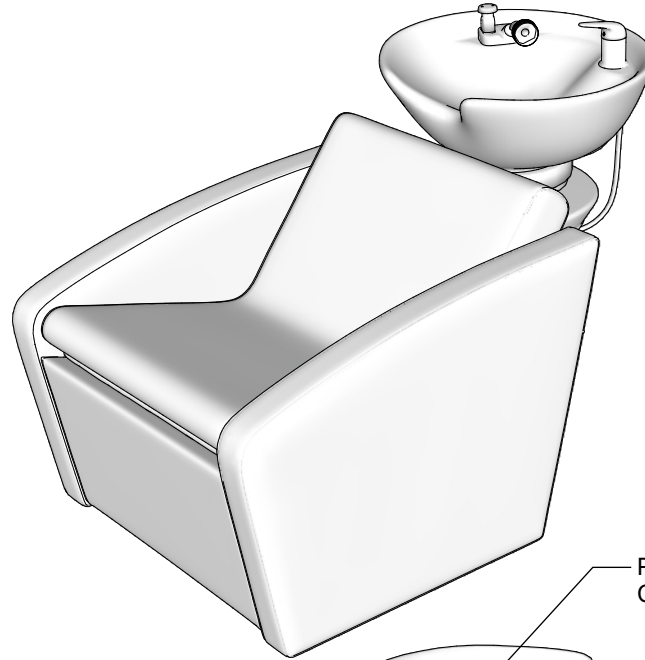
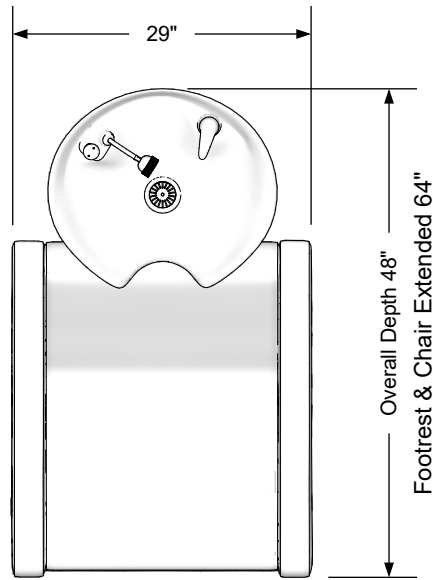

### Additional Information

Assembly required - yes  
 Electrical required - yes  
 Plumbing required - yes  
 Wall blocking required - no  
 Other (specify) - n/a  
 Other (specify) - n/a  
 Other (specify) - n/a  
 Other (specify) - n/a

### Specification Drawing

This **Specification Drawing** is intended for communicating the basic description, function, appearance, dimensions, features, and installation of an item as manufactured by Collins Manufacturing Company. Because this drawing does not contain project specific information such as quantities, finishes, or options, it is not an approval drawing and does not require a signature. This drawing remains the property of Collins Manufacturing Company and must not be used against the interests of Collins Manufacturing Company.

### Product Information

<b>collins</b>		Collins Manufacturing 2000 Bowser Road Cookeville, TN 38506	
Name: <b>VEECO Tranquility Elec. Shampoo Unit</b>			
Size: <b>NTS</b>	Part Number: <b>2850.B</b>	Drawn By: <b>Eng</b>	
Prepared Date: <b>2/11/21</b>	Revision Date: <b>Date</b>	Revision Number: <b>Rev #</b>	Sheet: <b>1 of 3</b>

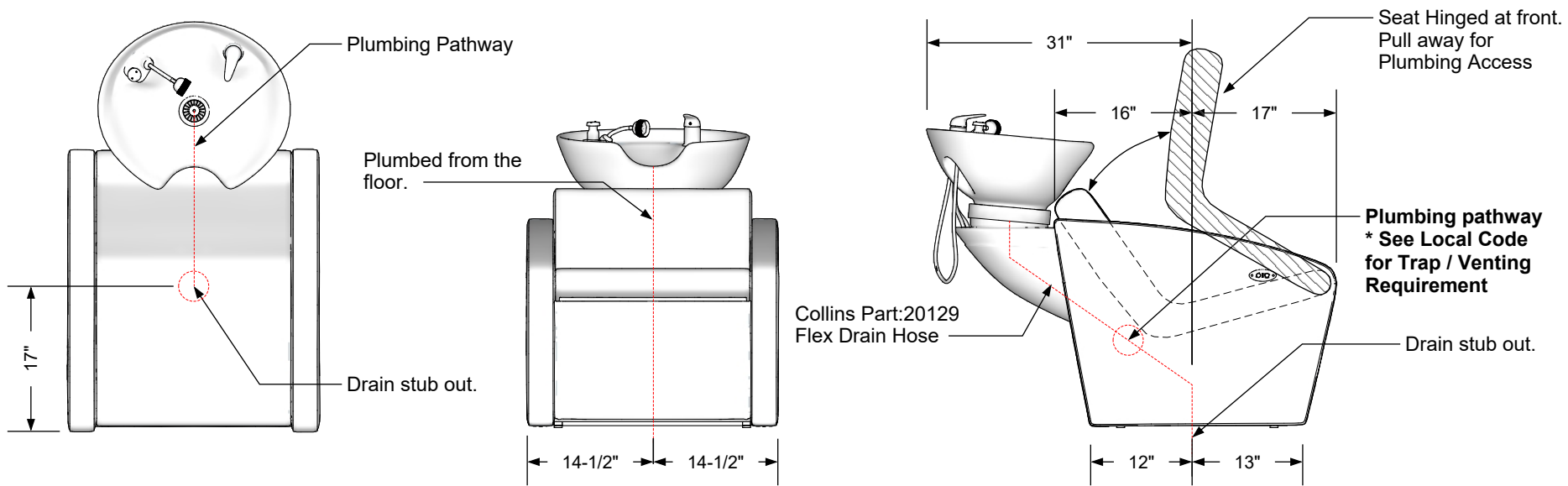

**Plumbing stub out detail**  
**\*Please Consult Local Codes**

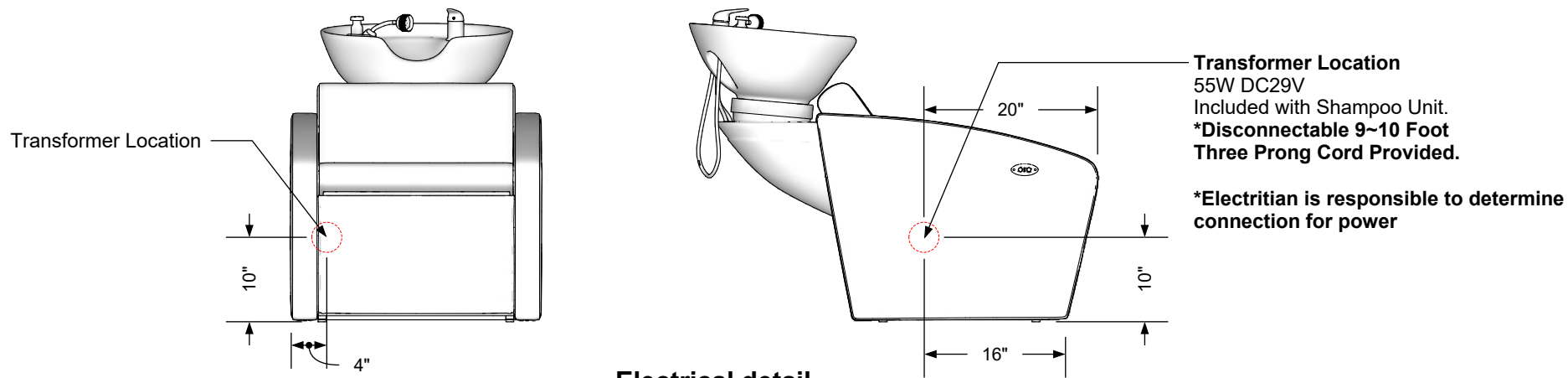

**Electrical detail**

**Additional Information**

Assembly required - yes  
 Electrical required - yes  
 Plumbing required - yes  
 Wall blocking required - no  
 Other (specify) - n/a  
 Other (specify) - n/a  
 Other (specify) - n/a  
 Other (specify) - n/a

**Specification Drawing**

This **Specification Drawing** is intended for communicating the basic description, function, appearance, dimensions, features, and installation of an item as manufactured by Collins Manufacturing Company. Because this drawing does not contain project specific information such as quantities, finishes, or options, it is not an approval drawing and does not require a signature. This drawing remains the property of Collins Manufacturing Company and must not be used against the interests of Collins Manufacturing Company.

**Product Information**

		Collins Manufacturing 2000 Bowser Road Cookeville, TN 38506	
Name: <b>VEECO Tranquility Elec. Shampoo Unit</b>			
Size: <b>NTS</b>	Part Number: <b>2850.B</b>	Drawn By: <b>Eng</b>	
Prepared Date: <b>2/11/21</b>	Revision Date: <b>Date</b>	Revision Number: <b>Rev #</b>	Sheet: <b>2 of 3</b>

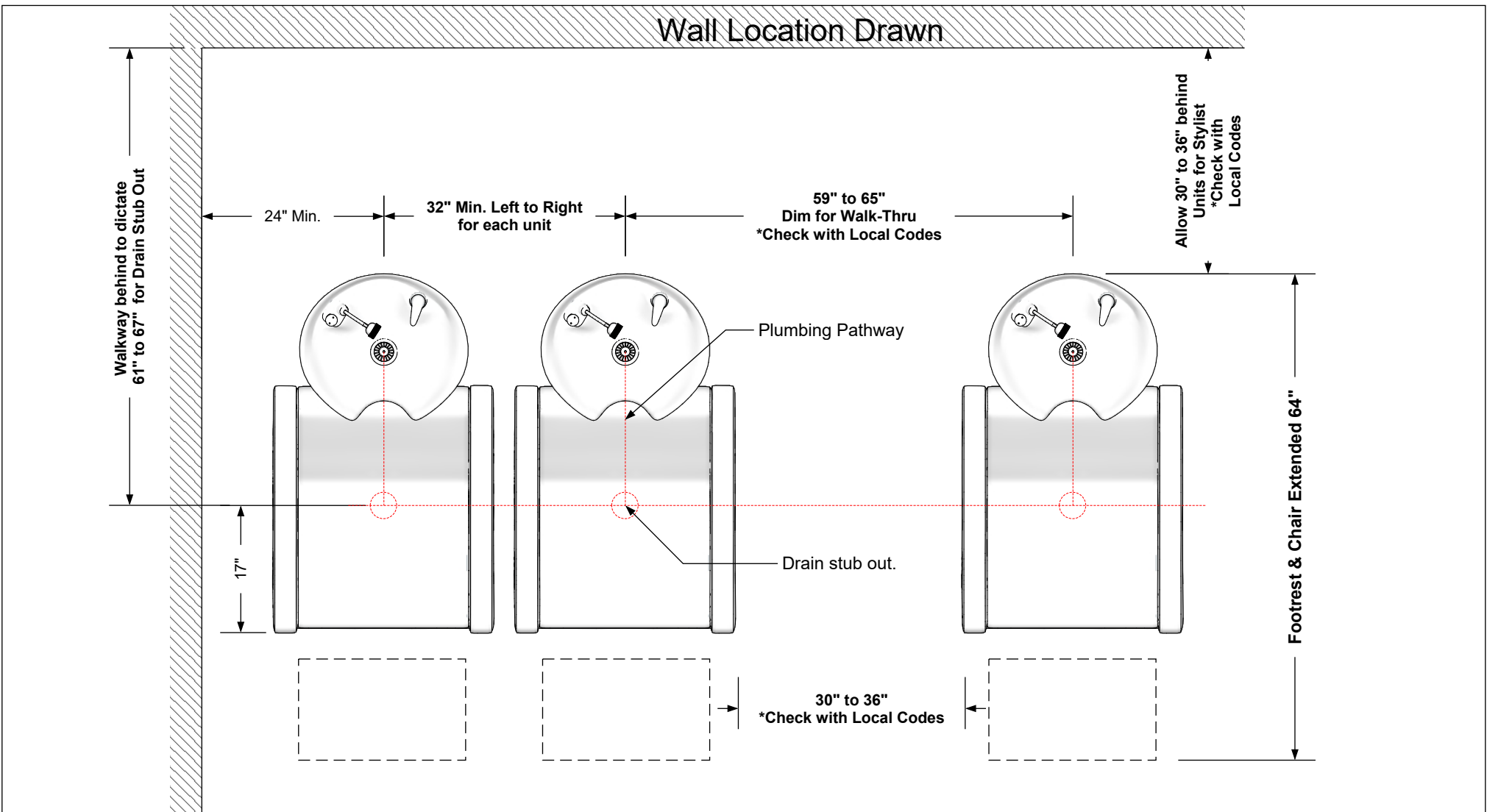

**Multi Unit Recommended Spacing Configuration**  
**\*Please Consult Local Codes**

**Additional Information**

Assembly required - yes  
 Electrical required - yes  
 Plumbing required - yes  
 Wall blocking required - no  
 Other (specify) - n/a  
 Other (specify) - n/a  
 Other (specify) - n/a  
 Other (specify) - n/a

**Specification Drawing**

This **Specification Drawing** is intended for communicating the basic description, function, appearance, dimensions, features, and installation of an item as manufactured by Collins Manufacturing Company. Because this drawing does not contain project specific information such as quantities, finishes, or options, it is not an approval drawing and does not require a signature. This drawing remains the property of Collins Manufacturing Company and must not be used against the interests of Collins Manufacturing Company.

**Product Information**

<b>collins</b>		Collins Manufacturing 2000 Bowser Road Cookeville, TN 38506	
Name: <b>VEECO Tranquility Elec. Shampoo Unit</b>			
Size: <b>NTS</b>	Part Number: <b>2850.B</b>	Drawn By: <b>Eng</b>	
Prepared Date: <b>2/11/21</b>	Revision Date: <b>Date</b>	Revision Number: <b>Rev #</b>	Sheet: <b>3 of 3</b>