



DOUBLE SIDED PORTABLE COMBO DESK / MANNEQUIN WORKSTATION FOR FOUR STUDENTS

SKU:2463-72

This salon workstation is the perfect all-in-one solution to create, style and teach from within your school. Features double sided shelving to accommodate four students.

Includes a mannequin holder, built in tool holders for easy access to all of your products, convenient electrical outlets so you can power up your tools, shelving for storage, and heavy duty locking casters so you can safely move it around.

TECHNICAL INFORMATION

- 72"W x 30"D x 34"H
- Reinforced legs
- Lockable heavy/duty casters

SHIPPING INFORMATION

Item generally ships via Freight(Truck) service

- Weight: 550 lbs
- Dimensions: 84"L x 36"W x 42"H

WARRANTY

3 Years:

- Ball-Bearing Drawer Slides
- Cabinet hinges

1 Year:

- All remaining components, unless noted otherwise, are guaranteed for a period of one year from the date of purchase.



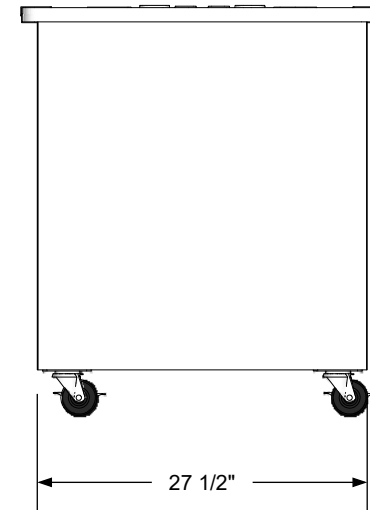
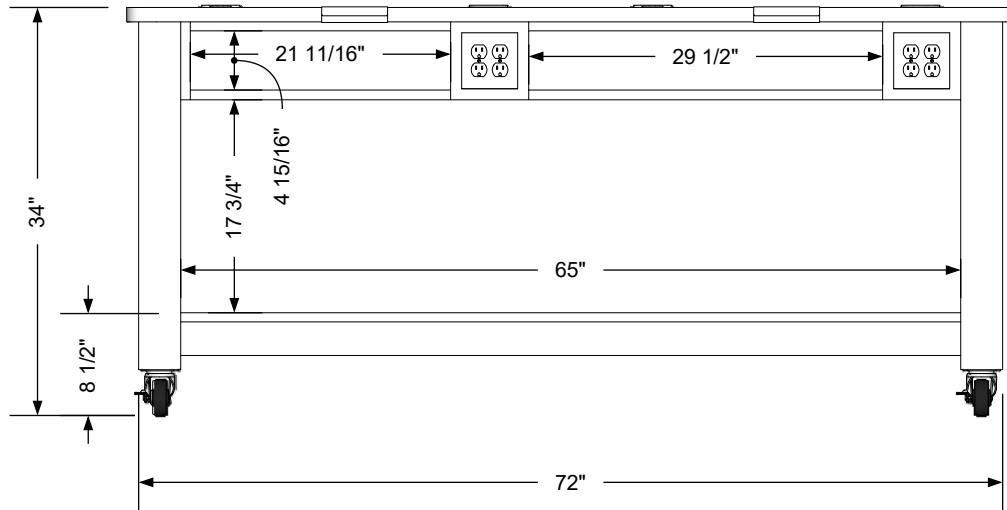
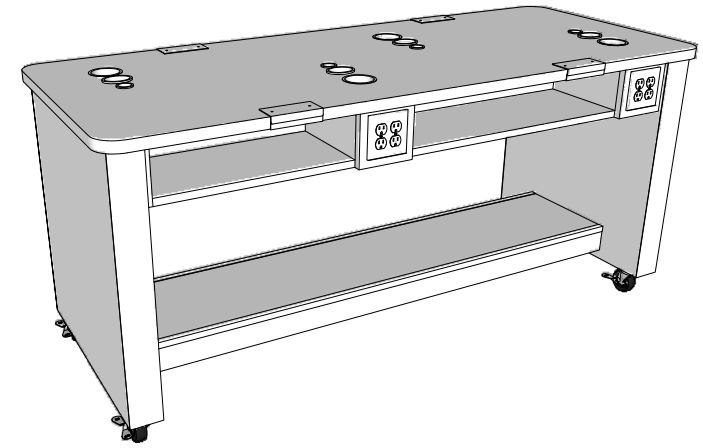
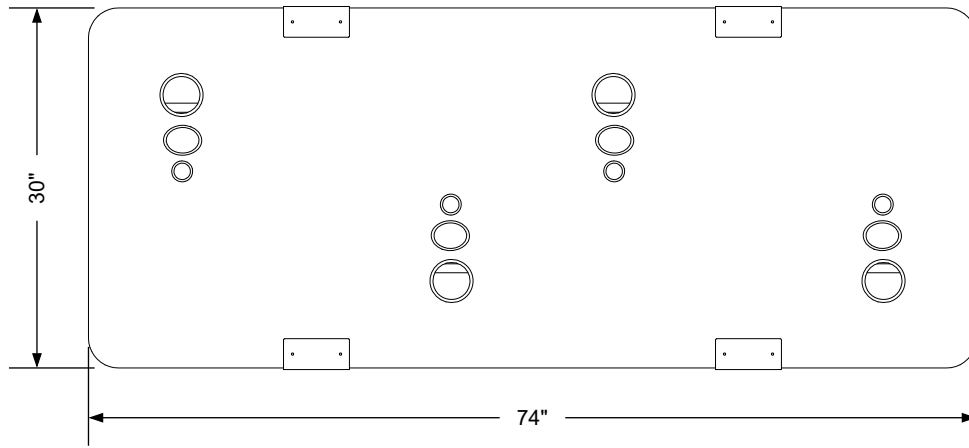

Additional Information

Assembly required - yes
 Electrical required - yes
 Plumbing required - no
 Wall blocking required - no
 COM yardage/laminate usage - 104 sf
 Laminated legs + locking casters
 Other (specify) - n/a
 Other (specify) - n/a

Specification Drawing

This **Specification Drawing** is intended for communicating the basic description, function, appearance, dimensions, features, and installation of an item as manufactured by Collins Manufacturing Company. Because this drawing does not contain project specific information such as quantities, finishes, or options, it is not an approval drawing and does not require a signature. This drawing remains the property of Collins Manufacturing Company and must not be used against the interests of Collins Manufacturing Company.

Product Information

		Collins Manufacturing 2000 Bowser Road Cookeville, TN 38506	
Name: Double Sided Portable Combo Desk And Mannequin Workstation for Four Students - 72			
Size:	Part Number:	Drawn By:	
NTS	2463-72	Eng	
Prepared Date:	Revision Date:	Revision Number:	Sheet:
7/1/20	Date	Rev #	1 of 2

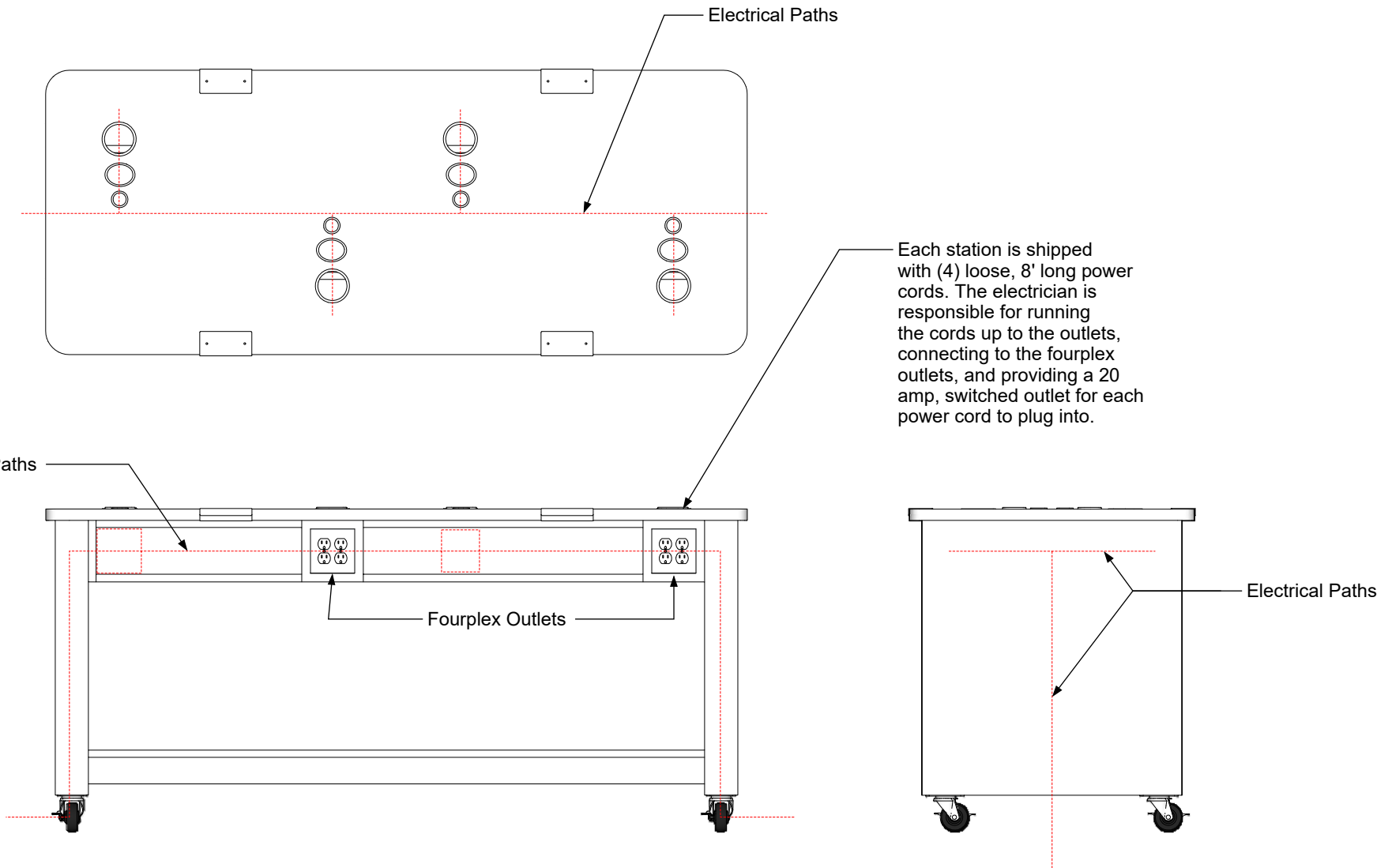

Electrical stub out detail

Additional Information

Assembly required - yes
 Electrical required - yes
 Plumbing required - no
 Wall blocking required - no
 COM yardage/laminate usage - 104 sf
 Laminated legs + locking casters
 Other (specify) - n/a
 Other (specify) - n/a

Specification Drawing

This **Specification Drawing** is intended for communicating the basic description, function, appearance, dimensions, features, and installation of an item as manufactured by Collins Manufacturing Company. Because this drawing does not contain project specific information such as quantities, finishes, or options, it is not an approval drawing and does not require a signature. This drawing remains the property of Collins Manufacturing Company and must not be used against the interests of Collins Manufacturing Company.

Product Information

		Collins Manufacturing 2000 Bowser Road Cookeville, TN 38506	
Name: Double Sided Portable Combo Desk And Mannequin Workstation for Four Students - 72			
Size:	Part Number:	Drawn By:	
NTS	2463-72	Eng	
Prepared Date:	Revision Date:	Revision Number:	Sheet:
7/1/20	Date	Rev #	2 of 2