



CAMEO EDU NAIL TABLE

SKU:2264-42

The Cameo Nail Table is the perfect solution for a small working space. With storage and casters, this portable tabletop makes it easy to move from room to room and workstation to workstation.

TECHNICAL INFORMATION

- Measures: 42"W x 18"D x 30"H
- 1 Full extension drawer
- 15" Wide storage cabinet w/ adjustable shelf
- Caster
- Padder rest
- Lamp
- Soft radius
- Optional: 120/40 Valentino powered vent w/ charcoal filter

SHIPPING INFORMATION

Item generally ships via Freight(Truck) service

- Weight: 160 lbs
- Dimensions: 48"L x 32"W x 40"H

WARRANTY

3 Years:

- Ball-Bearing Drawer Slides
- Cabinet hinges

1 Year:

- All remaining components, unless noted otherwise, are guaranteed for a period of one year from the date of purchase.



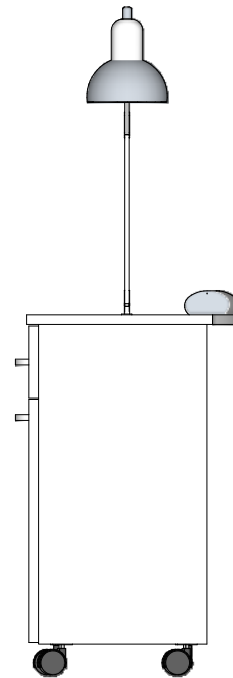
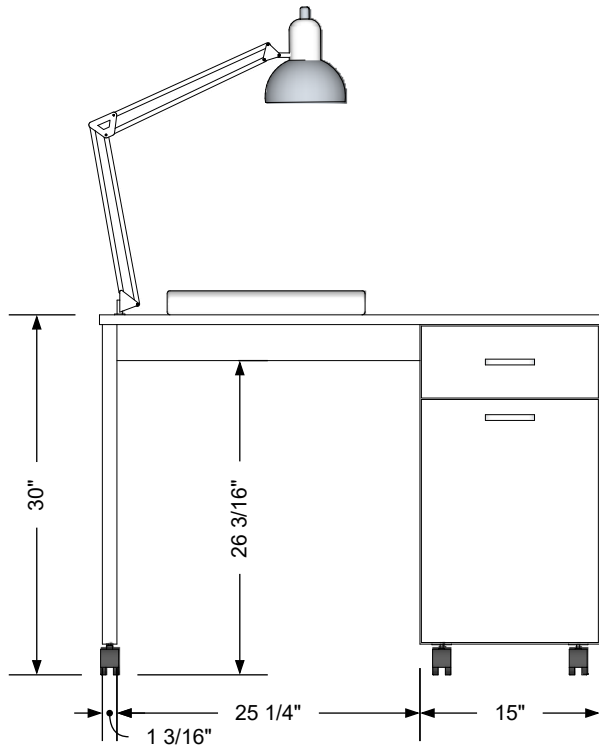
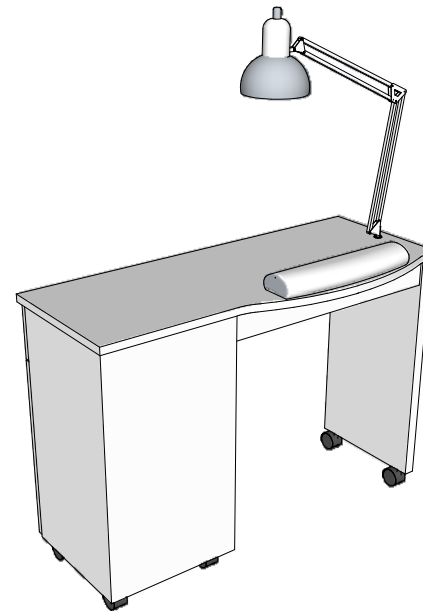
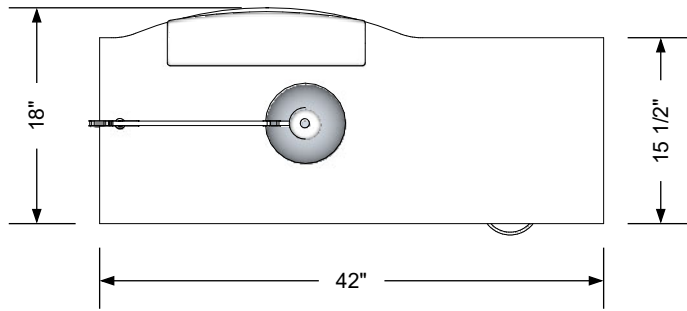

Additional Information

Assembly required - no
 Electrical required - yes
 Plumbing required - no
 Wall blocking required - no
 COM yardage/laminate usage - 38 sf
 2 1/2" h Twinwheel casters
 Other (specify) - n/a
 Other (specify) - n/a

Specification Drawing

This **Specification Drawing** is intended for communicating the basic description, function, appearance, dimensions, features, and installation of an item as manufactured by Collins Manufacturing Company. Because this drawing does not contain project specific information such as quantities, finishes, or options, it is not an approval drawing and does not require a signature. This drawing remains the property of Collins Manufacturing Company and must not be used against the interests of Collins Manufacturing Company.

Product Information

collins		Collins Manufacturing 2000 Bowser Road Cookeville, TN 38506	
Name: Cameo Nail Table			
Size: NTS	Part Number: 2264-42	Drawn By: Eng	
Prepared Date: 5/22/20	Revision Date: Date	Revision Number: Rev #	Sheet: 1 of 2

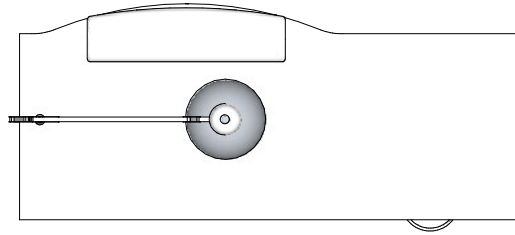

There is no power strip or outlet included with this unit. Electrician to provide, install, and wire a 15 amp outlet installed in the wall or floor within reach of the lamp's 59" long cord.

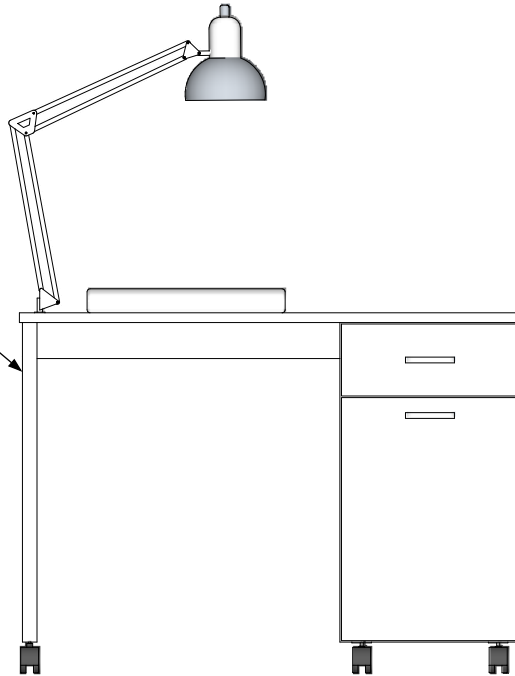

Electrical stub out detail

Additional Information

Assembly required - no
 Electrical required - yes
 Plumbing required - no
 Wall blocking required - no
 COM yardage/laminate usage - 38 sf
 2 1/2" h Twinwheel casters
 Other (specify) - n/a
 Other (specify) - n/a

Specification Drawing

This **Specification Drawing** is intended for communicating the basic description, function, appearance, dimensions, features, and installation of an item as manufactured by Collins Manufacturing Company. Because this drawing does not contain project specific information such as quantities, finishes, or options, it is not an approval drawing and does not require a signature. This drawing remains the property of Collins Manufacturing Company and must not be used against the interests of Collins Manufacturing Company.

Product Information

		Collins Manufacturing 2000 Bowser Road Cookeville, TN 38506	
Name: Cameo Nail Table			
Size: NTS	Part Number: 2264-42	Drawn By: Eng	
Prepared Date: 5/22/20	Revision Date: Date	Revision Number: Rev #	Sheet: 2 of 2