

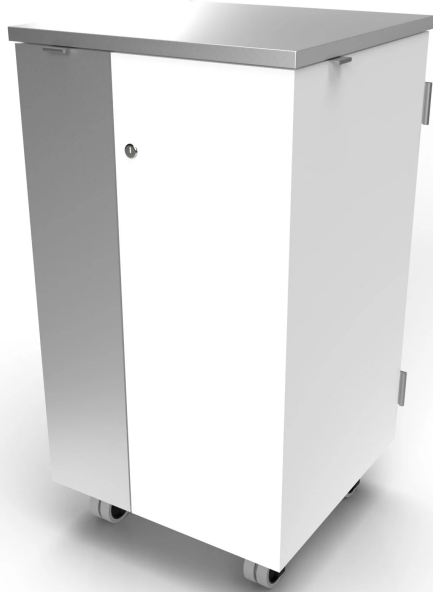

CRAZY CAB CART

SKU:2107-18



The Crazy Cart is the ultimate mobile styling cart. Built-in tool holders, a pull-out storage section for tall products and smaller items like brushes, and a stainless steel top with 80 grit finish complete with customizable panels make this portable styling station everything you need no matter where you go.

TECHNICAL INFORMATION

- 18"W x 18"D x 36"H
- Stainless steel top
- Four industrial grade non-marring rubber casters
- Built in tall storage spice drawer with adjustable center shelf
- Concealed tool shelf
- 6-plug power strip with 6 foot cord

SHIPPING INFORMATION

Item generally ships via Freight(Truck) service

- Weight: 150 lbs
- Dimensions: 32"L x 30"W x 44"H

WARRANTY

3 Years:

- Ball-Bearing Drawer Slides
- Cabinet hinges

1 Year:

- All remaining components, unless noted otherwise, are guaranteed for a period of one year from the date of purchase.



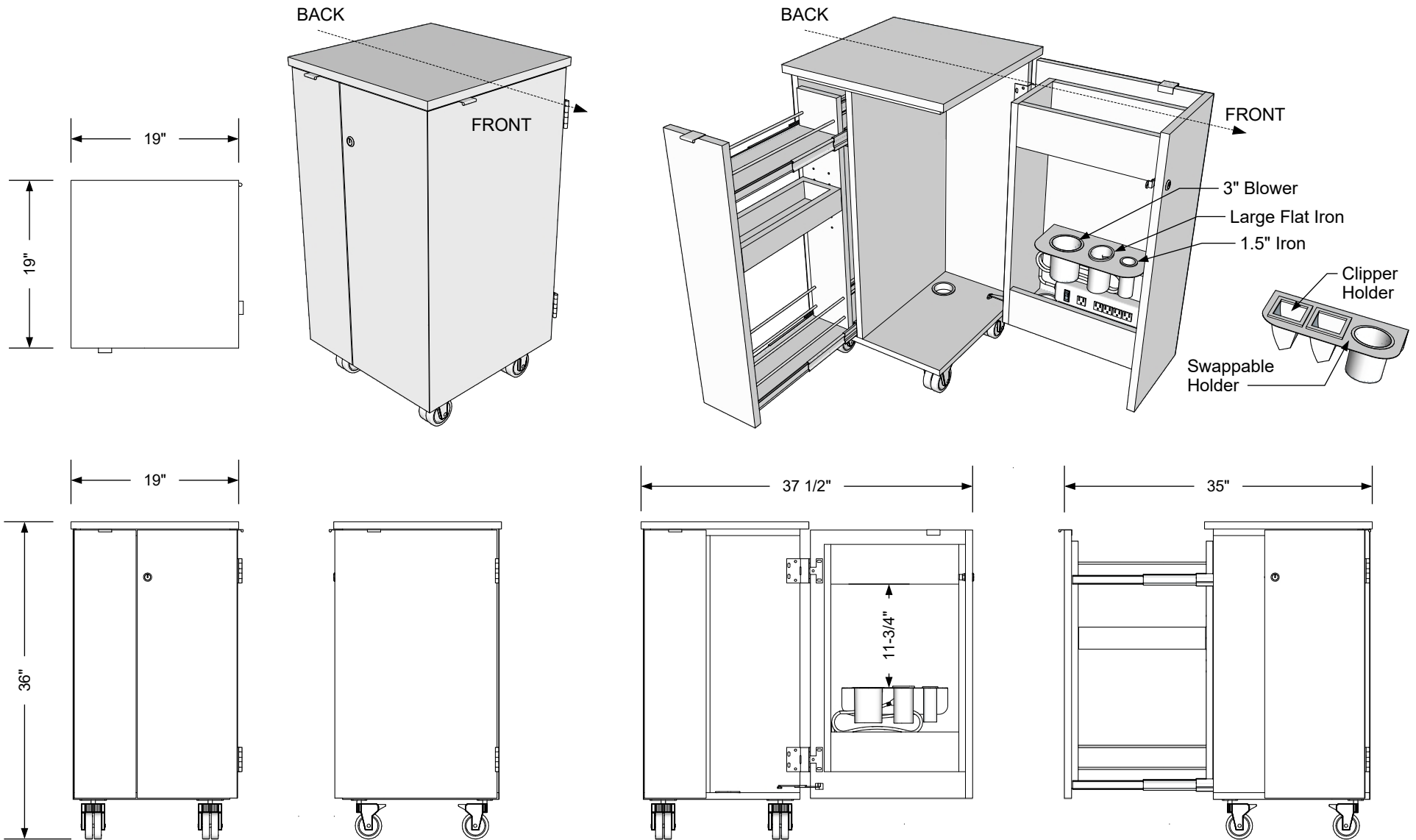

Additional Information

Assembly required - no
 Electrical required -yes
 Plumbing required - no
 Wall blocking required - no
 COM yardage/laminate usage - 24 sf
 4 1/2" h Double Wheel Casters
 Other (specify) - n/a
 Other (specify) - n/a

Specification Drawing

This **Specification Drawing** is intended for communicating the basic description, function, appearance, dimensions, features, and installation of an item as manufactured by Collins Manufacturing Company. Because this drawing does not contain project specific information such as quantities, finishes, or options, it is not an approval drawing and does not require a signature. This drawing remains the property of Collins Manufacturing Company and must not be used against the interests of Collins Manufacturing Company.

Product Information

		Collins Manufacturing 2000 Bowser Road Cookeville, TN 38506	
Name: Crazy Cab Cart			
Size: NTS	Part Number: 2107-18	Drawn By: Eng	
Prepared Date: 5/12/20	Revision Date: 10/21/20	Revision Number: Rev 1	Sheet: 1 of 2

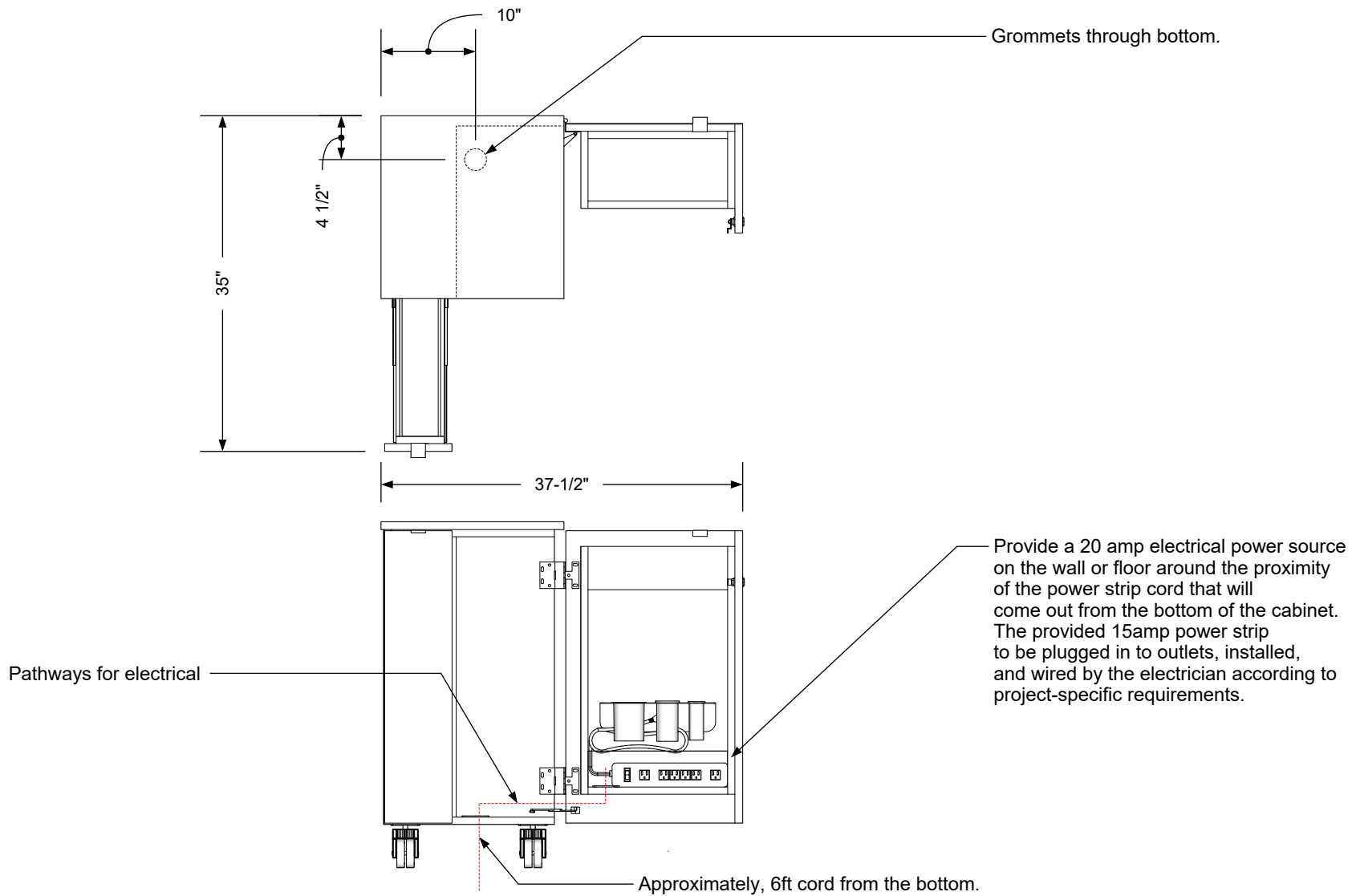

Electrical stub out detail

Additional Information

Assembly required - no
 Electrical required -yes
 Plumbing required - no
 Wall blocking required - no
 COM yardage/laminate usage - 24 sf
 4 1/2" h Double Wheel Casters
 Other (specify) - n/a
 Other (specify) - n/a

Specification Drawing

This **Specification Drawing** is intended for communicating the basic description, function, appearance, dimensions, features, and installation of an item as manufactured by Collins Manufacturing Company. Because this drawing does not contain project specific information such as quantities, finishes, or options, it is not an approval drawing and does not require a signature. This drawing remains the property of Collins Manufacturing Company and must not be used against the interests of Collins Manufacturing Company.

Product Information

		Collins Manufacturing 2000 Bowser Road Cookeville, TN 38506	
Name: Crazy Cab Cart			
Size: NTS	Part Number: 2107-18	Drawn By: Eng	
Prepared Date: 5/12/20	Revision Date: 10/21/20	Revision Number: Rev 1	Sheet: 2 of 2