



VERSA B2B

SKU:2120-36

As cosmetology classes change from barber to styling, so too does the Versa station. Each Versa comes standard w/ two styling and two flat panel tool panels. Also available is a barbering tool panel and a Marcel styling tool panel, ordered separately.

TECHNICAL INFORMATION

- 36"W x 28.5"D x 84"H
- Powder coated steel uprights
- Four stainless steel tool panels of your choice
- Drawer on each side w/ full-width ledge
- 24" x 48" mirrors
- Quad-plex outlets
- Purse hook

SHIPPING INFORMATION

Item generally ships via Freight(Truck) service

- Weight: 285 lbs
- Dimensions: 2 pallets

WARRANTY

3 Years:

- Ball-Bearing Drawer Slides
- Cabinet hinges

1 Year:

- All remaining components, unless noted otherwise, are guaranteed for a period of one year from the date of purchase.



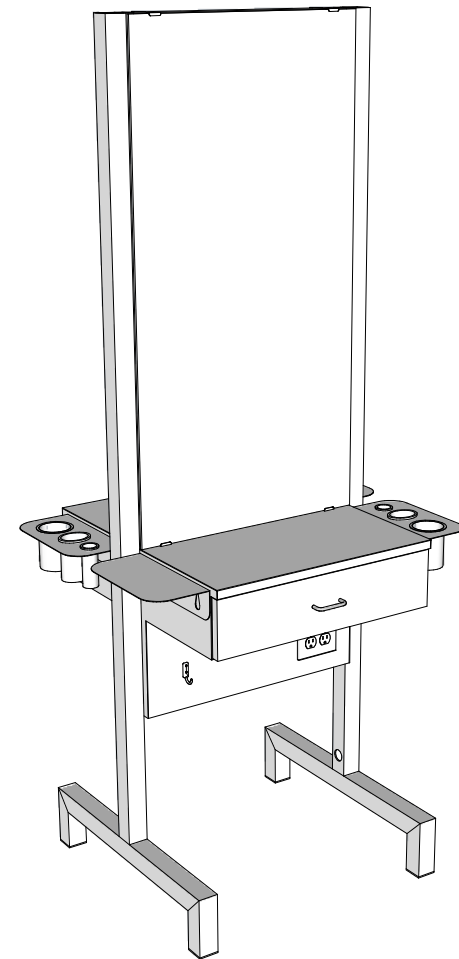
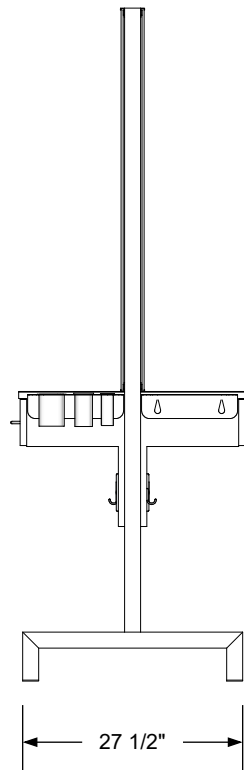
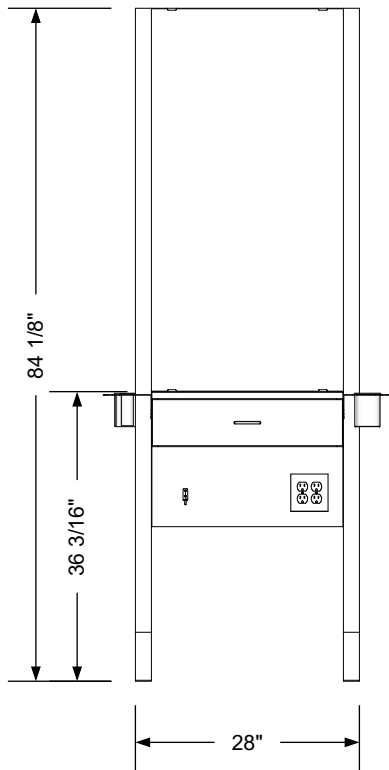
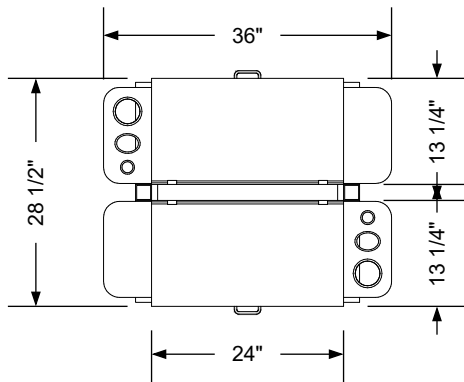

Additional Information

Assembly required - yes
 Electrical required - yes
 Plumbing required - no
 Wall blocking required - no
 COM yardage/laminate usage - 24 sf
 1/8"h Plastic inserts in the bottom of legs
 Other (specify) - n/a
 Other (specify) - n/a

Specification Drawing

This **Specification Drawing** is intended for communicating the basic description, function, appearance, dimensions, features, and installation of an item as manufactured by Collins Manufacturing Company. Because this drawing does not contain project specific information such as quantities, finishes, or options, it is not an approval drawing and does not require a signature. This drawing remains the property of Collins Manufacturing Company and must not be used against the interests of Collins Manufacturing Company.

Product Information

		Collins Manufacturing 2000 Bowser Road Cookeville, TN 38506	
Name: Versa B2B			
Size: NTS	Part Number: 2120-36	Drawn By: Eng	
Prepared Date: 4/25/20	Revision Date: Date	Revision Number: Rev #	Sheet: 1 of 2

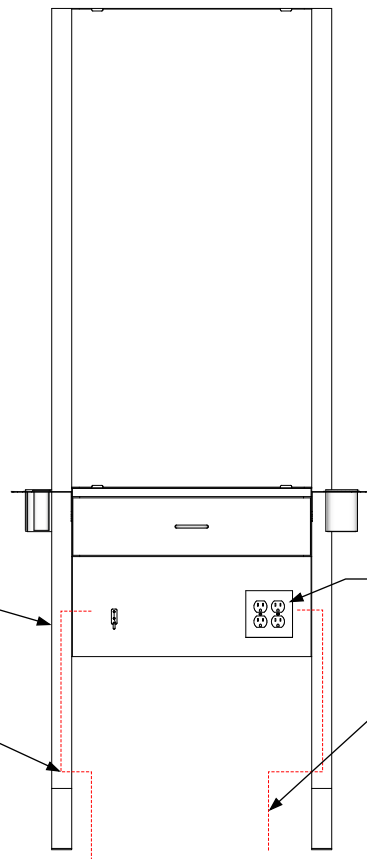

Fourplex outlets

Each station is shipped with (2) loose, 8' long power cords. The electrician is responsible for running the cords up through the legs, connecting to the fourplex outlets, and providing a 20 amp, switched outlet for each power cord to plug into.

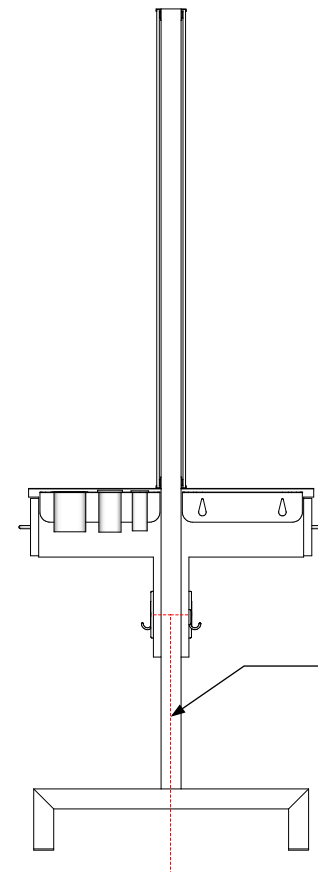

Pathways for electrical

Electrical stub out detail

Additional Information

Assembly required - yes
 Electrical required - yes
 Plumbing required - no
 Wall blocking required - no
 COM yardage/laminate usage - 24 sf
 1/8" Plastic inserts in the bottom of legs
 Other (specify) - n/a
 Other (specify) - n/a

Specification Drawing

This **Specification Drawing** is intended for communicating the basic description, function, appearance, dimensions, features, and installation of an item as manufactured by Collins Manufacturing Company. Because this drawing does not contain project specific information such as quantities, finishes, or options, it is not an approval drawing and does not require a signature. This drawing remains the property of Collins Manufacturing Company and must not be used against the interests of Collins Manufacturing Company.

Product Information

		Collins Manufacturing 2000 Bowser Road Cookeville, TN 38506	
Name: Versa B2B			
Size: NTS	Part Number: 2120-36	Drawn By: Eng	
Prepared Date: 4/25/20	Revision Date: Date	Revision Number: Rev #	Sheet: 2 of 2