



QUAD BARBER ISLAND

SKU:2311-100



This Quad Barber Island is one of the most popular barber stations on the market. The sleek and modern look of this station adds a touch of class, while still being extremely functional for your salon or school. Configured for 4 students to work at once, with a shared sink in-between each side.

Each station also has a built in tool holder and tool hooks so students can safely store their tools and keep them within arms reach while working. A drawer is also included with each station which makes it easier to find additional supplies when needed.

TECHNICAL INFORMATION

- 100"W x 32"D x 82"H
- Powder coated steel frames
- Two ADA stainless sinks with gooseneck faucets in center of each side
- Drawer
- Outlet
- Tool holders
- Hooks for each barber student

SHIPPING INFORMATION

Item generally ships via Freight(Truck) service

- Weight: 1050 lbs
- Dimensions: 3 pallets

WARRANTY

5 YEARS:

- Sol Air dryer motors & hoods

3 YEARS:

- Molded urethane arms
- Upholstery

2 YEARS:

- Jeffco K500 and Collins 2200 dryers

1 YEAR:

- All remaining components, unless noted otherwise

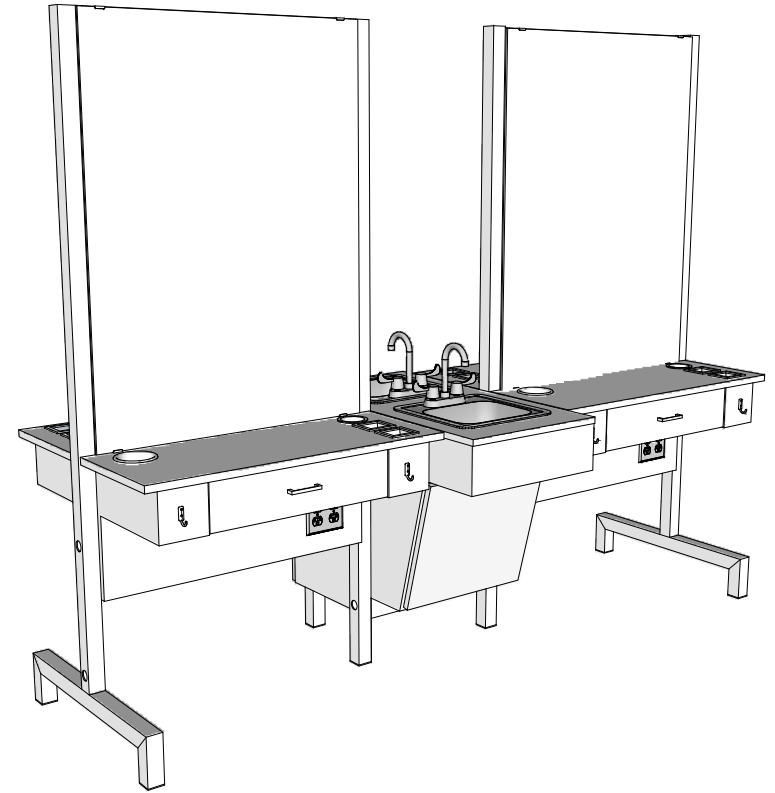
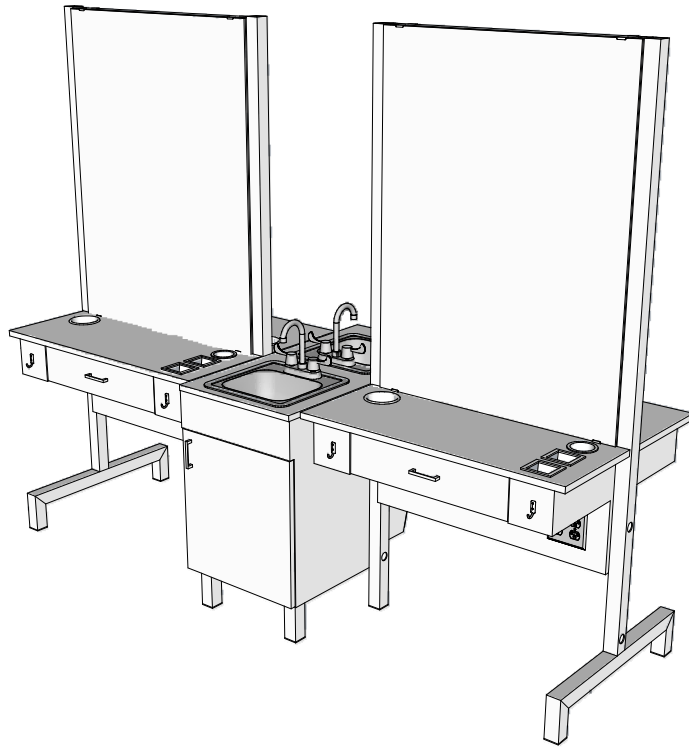

Additional Information

Assembly required - yes
 Electrical required - yes
 Plumbing required - yes
 Wall blocking required - no
 COM yardage/laminate usage - 135 sf
 1/8" Plastic inserts in the bottom of legs
 Other (specify) - n/a
 Other (specify) - n/a

Specification Drawing

This **Specification Drawing** is intended for communicating the basic description, function, appearance, dimensions, features, and installation of an item as manufactured by Collins Manufacturing Company. Because this drawing does not contain project specific information such as quantities, finishes, or options, it is not an approval drawing and does not require a signature. This drawing remains the property of Collins Manufacturing Company and must not be used against the interests of Collins Manufacturing Company.

Product Information

		Collins Manufacturing 2000 Bowser Road Cookeville, TN 38506	
Name: Quad Barber Island			
Size: NTS	Part Number: 2311-100	Drawn By: Eng	
Prepared Date: 6/6/20	Revision Date: Date	Revision Number: Rev #	Sheet: 1 of 4

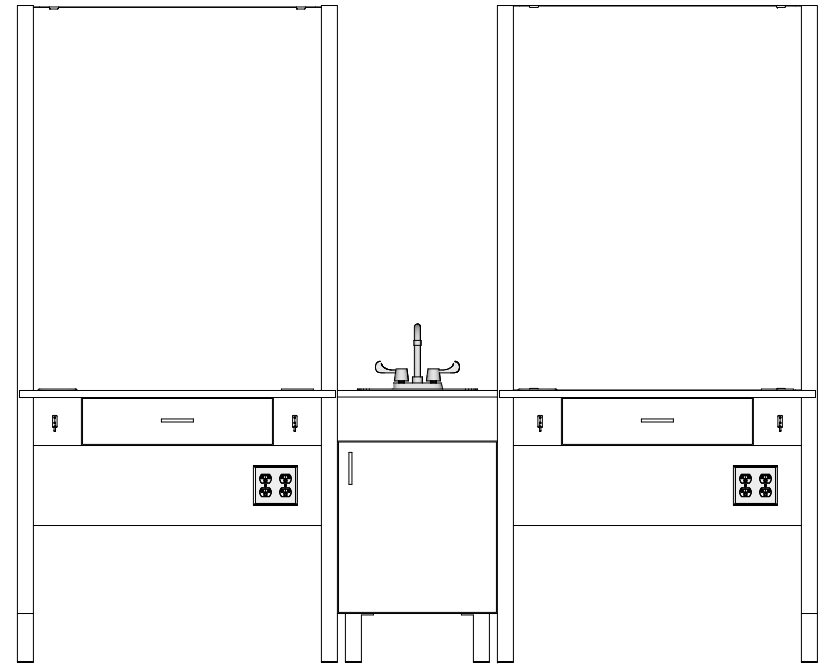
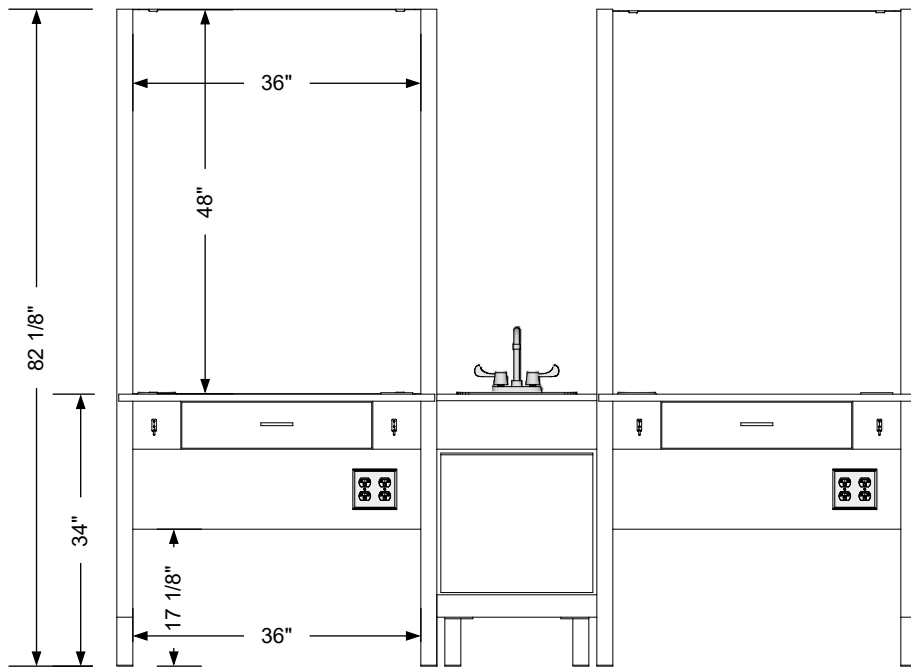
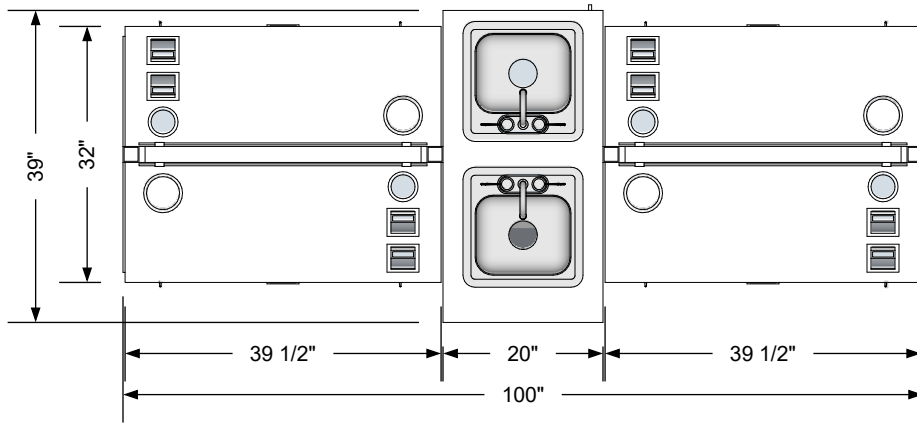

Additional Information

Assembly required - yes
 Electrical required - yes
 Plumbing required - yes
 Wall blocking required - no
 COM yardage/laminate usage - 135 sf
 1/8"h Plastic inserts in the bottom of legs
 Other (specify) - n/a
 Other (specify) - n/a

Specification Drawing

This **Specification Drawing** is intended for communicating the basic description, function, appearance, dimensions, features, and installation of an item as manufactured by Collins Manufacturing Company. Because this drawing does not contain project specific information such as quantities, finishes, or options, it is not an approval drawing and does not require a signature. This drawing remains the property of Collins Manufacturing Company and must not be used against the interests of Collins Manufacturing Company.

Product Information

		Collins Manufacturing 2000 Bowser Road Cookeville, TN 38506	
Name: Quad Barber Island			
Size: NTS	Part Number: 2311-100	Drawn By: Eng	
Prepared Date: 6/6/20	Revision Date: Date	Revision Number: Rev #	Sheet: 2 of 4

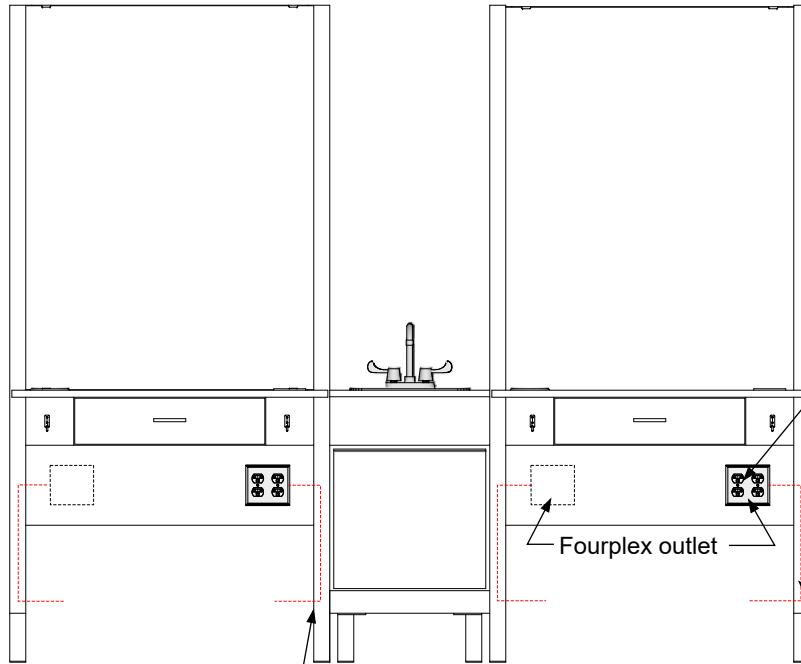
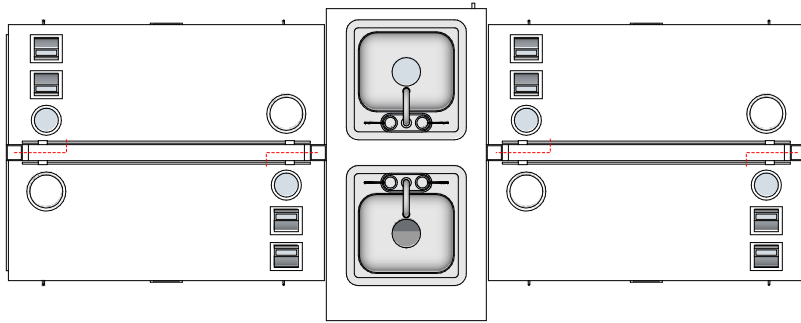

Each quad island is shipped with (4) loose, 8' long power cords. The electrician is responsible for running the cords up through the legs, connecting to the fourplex outlets, and providing a 20 amp, switched outlet for each power cord to plug into.

Grommets for provided power cords to pass through tubing and connect to the installed fourplex outlets in each side

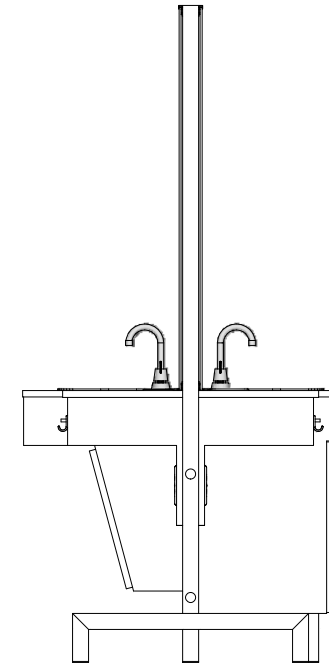

Electrical stub out detail

Additional Information

Assembly required - yes
 Electrical required - yes
 Plumbing required - yes
 Wall blocking required - no
 COM yardage/laminate usage - 135 sf
 1/8" Plastic inserts in the bottom of legs
 Other (specify) - n/a
 Other (specify) - n/a

Specification Drawing

This **Specification Drawing** is intended for communicating the basic description, function, appearance, dimensions, features, and installation of an item as manufactured by Collins Manufacturing Company. Because this drawing does not contain project specific information such as quantities, finishes, or options, it is not an approval drawing and does not require a signature. This drawing remains the property of Collins Manufacturing Company and must not be used against the interests of Collins Manufacturing Company.

Product Information

		Collins Manufacturing	
		2000 Bowser Road Cookeville, TN 38506	
Name: Quad Barber Island			
Size: NTS	Part Number: 2311-100	Drawn By: Eng	
Prepared Date: 6/6/20	Revision Date: Date	Revision Number: Rev #	Sheet: 3 of 4

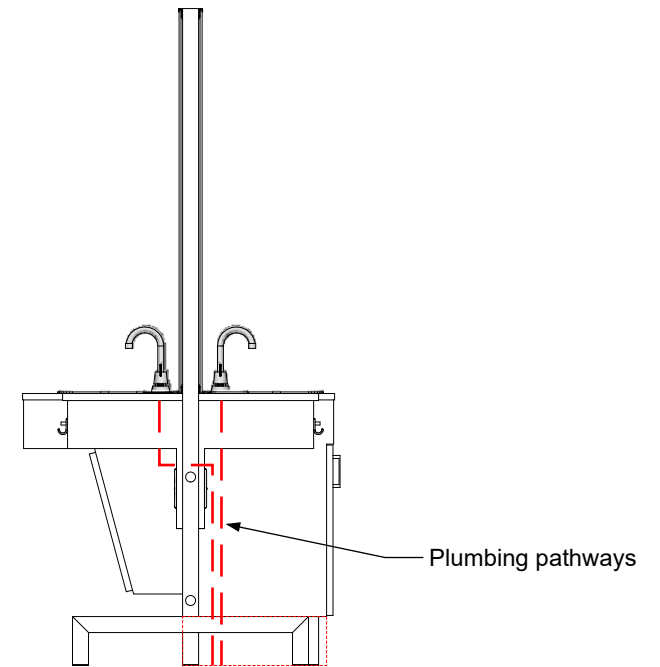
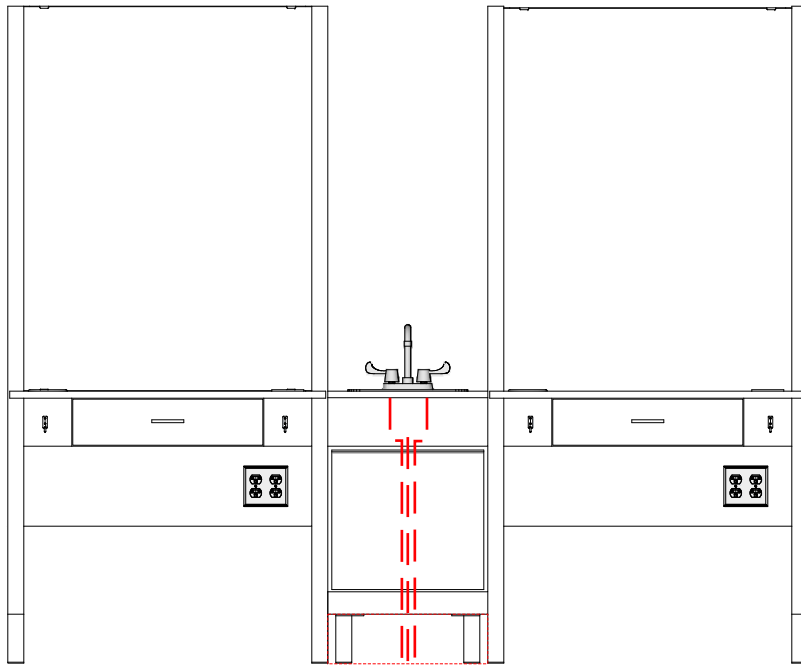
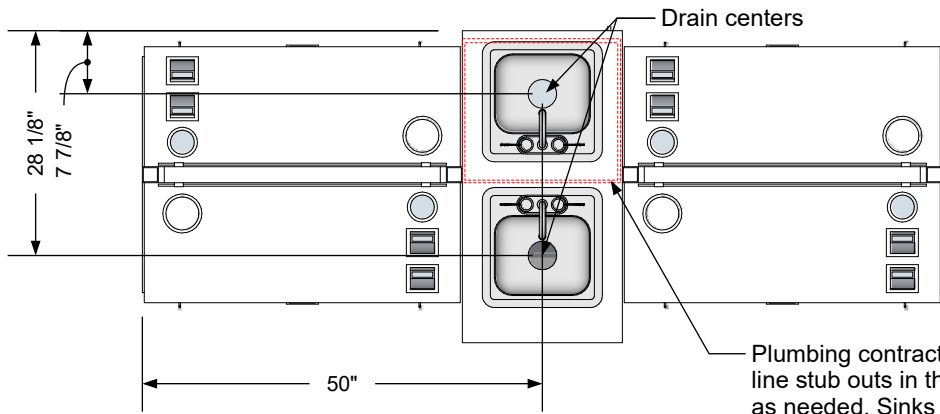

Plumbing stub out detail

Additional Information

Assembly required - yes
 Electrical required - yes
 Plumbing required - yes
 Wall blocking required - no
 COM yardage/laminate usage - 135 sf
 1/8" Plastic inserts in the bottom of legs
 Other (specify) - n/a
 Other (specify) - n/a

Specification Drawing

This **Specification Drawing** is intended for communicating the basic description, function, appearance, dimensions, features, and installation of an item as manufactured by Collins Manufacturing Company. Because this drawing does not contain project specific information such as quantities, finishes, or options, it is not an approval drawing and does not require a signature. This drawing remains the property of Collins Manufacturing Company and must not be used against the interests of Collins Manufacturing Company.

Product Information

collins		Collins Manufacturing 2000 Bowser Road Cookeville, TN 38506	
Name: Quad Barber Island			
Size: NTS	Part Number: 2311-100	Drawn By: Eng	
Prepared Date: 6/6/20	Revision Date: Date	Revision Number: Rev #	Sheet: 4 of 4