



## REDMAN MAKEUP VANITY

SKU:2691-42

Bring a modern touch to a classic style with our Redman makeup vanity. This piece features a stainless steel frame, Hollywood style lighting and three mirrors for a sleek look that's both chic and practical.



### TECHNICAL INFORMATION

---

- 42"W x 21"D x 66"H
- Veeco classic
- Three mirrors
- LED lighting
- Center drawer
- Tool holders
- Stainless steel frame
- Side storage bins with small glass jars

### SHIPPING INFORMATION

---

Item generally ships via Freight(Truck) service

- Weight: 300 lbs
- Dimensions: 2 pallets

### WARRANTY

---

#### 3 Years:

- Ball-Bearing Drawer Slides
- Cabinet hinges

#### 1 Year:

- All remaining components, unless noted otherwise, are guaranteed for a period of one year from the date of purchase.

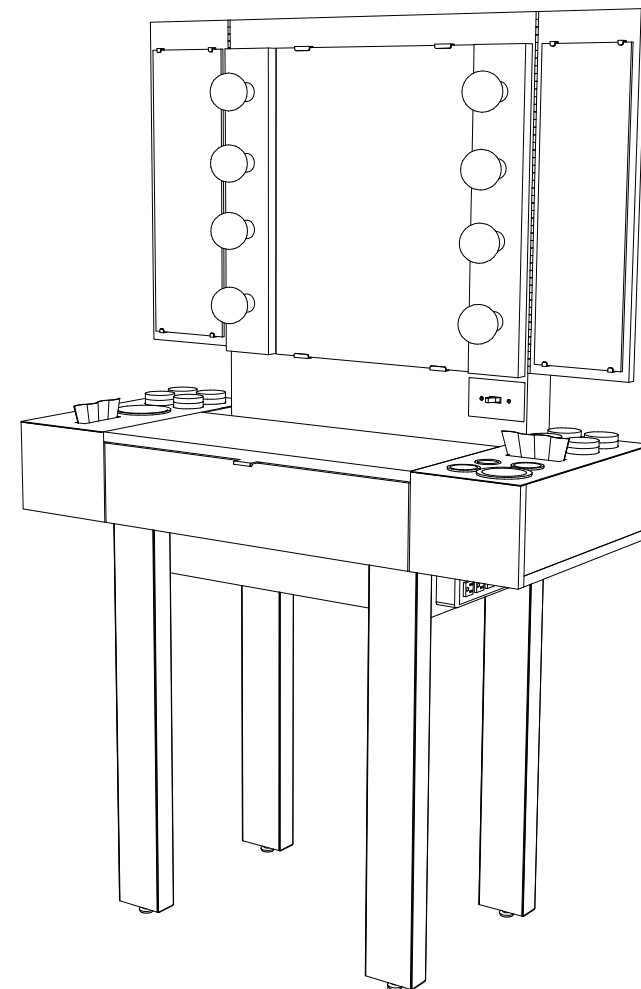
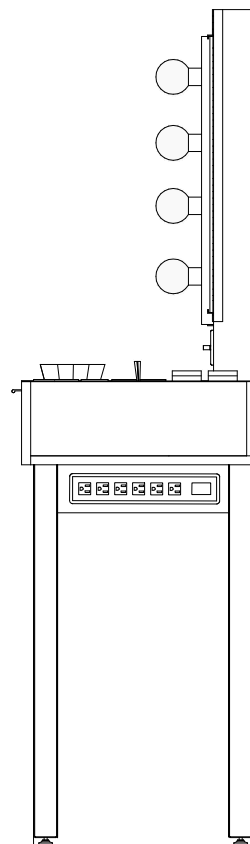
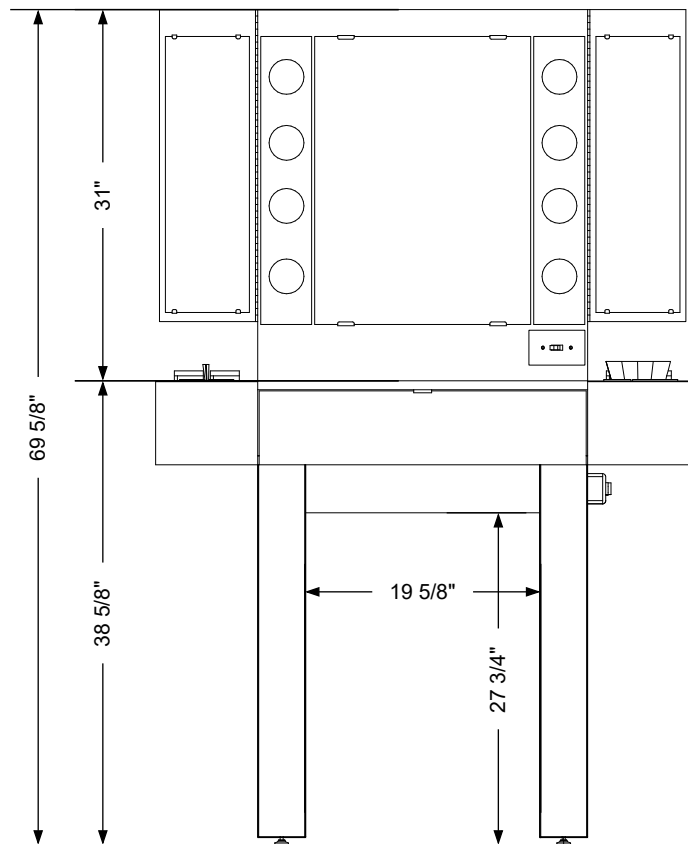
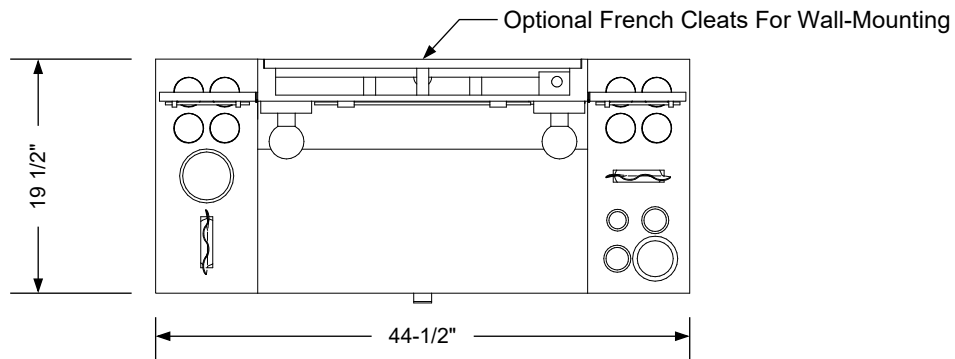

### Additional Information

Assembly required - yes  
 Electrical required - yes  
 Plumbing required - n/a  
 Wall blocking required - yes  
 COM yardage/laminate usage -  
 Metal Legs + 1/2"h Adj. glides  
 Other (specify) - n/a  
 Other (specify) - n/a

### Specification Drawing

This **Specification Drawing** is intended for communicating the basic description, function, appearance, dimensions, features, and installation of an item as manufactured by Collins Manufacturing Company. Because this drawing does not contain project specific information such as quantities, finishes, or options, it is not an approval drawing and does not require a signature. This drawing remains the property of Collins Manufacturing Company and must not be used against the interests of Collins Manufacturing Company.

### Product Information

		Collins Manufacturing 2000 Bowser Road Cookeville, TN 38506	
Name: <b>Redman Makeup Vanity</b>			
Size: <b>NTS</b>	Part Number: <b>2691-42</b>	Drawn By: <b>Eng</b>	
Prepared Date: <b>4/17/20</b>	Revision Date: <b>Date</b>	Revision Number: <b>Rev #</b>	Sheet: <b>1 of 2</b>

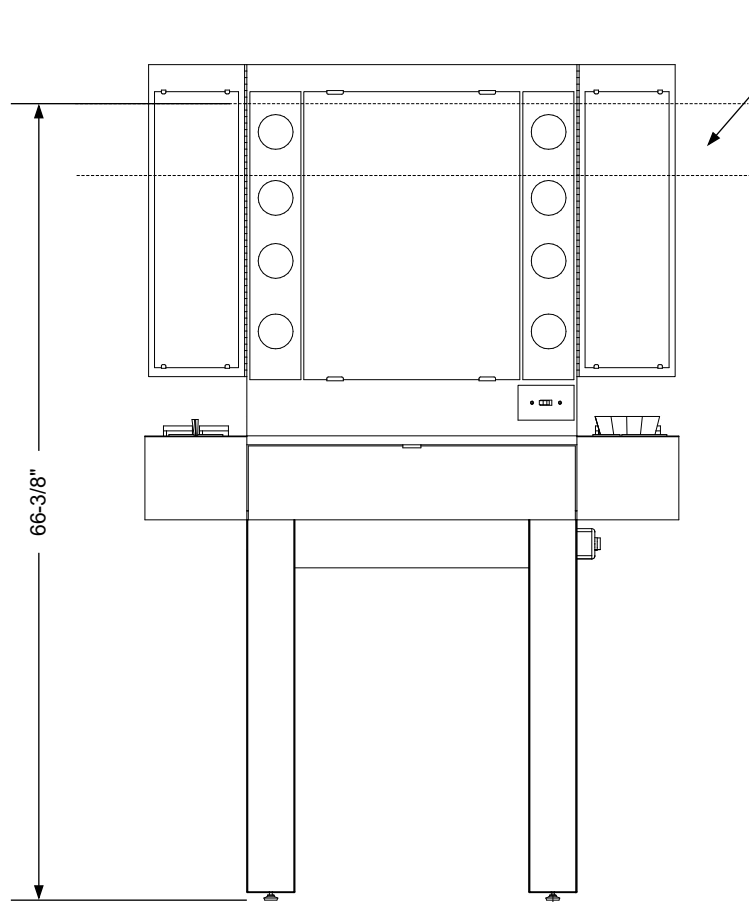

**Wall blocking detail**

2x6 Embedded wall blocking

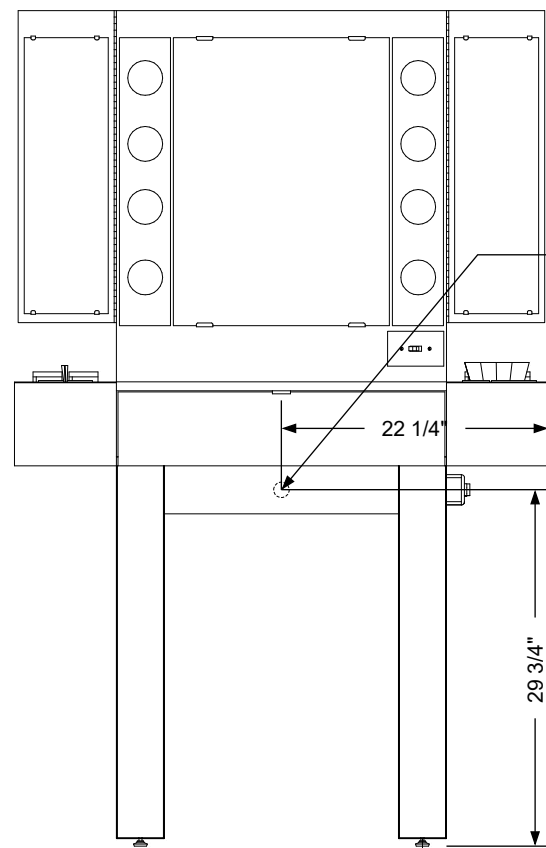

Electrical stub out - provide 15 amp, duplex outlet. Outlet to be provided & installed by the electrician.

**Electrical stub out detail**

**Additional Information**

Assembly required - yes  
 Electrical required - yes  
 Plumbing required - n/a  
 Wall blocking required - no  
 COM yardage/laminate usage -  
 Metal Legs + 1/2"h Adj. glides  
 Other (specify) - n/a  
 Other (specify) - n/a

**Specification Drawing**

This **Specification Drawing** is intended for communicating the basic description, function, appearance, dimensions, features, and installation of an item as manufactured by Collins Manufacturing Company. Because this drawing does not contain project specific information such as quantities, finishes, or options, it is not an approval drawing and does not require a signature. This drawing remains the property of Collins Manufacturing Company and must not be used against the interests of Collins Manufacturing Company.

**Product Information**

		Collins Manufacturing 2000 Bowser Road Cookeville, TN 38506	
Name: <b>Redman Makeup Vanity</b>			
Size: <b>NTS</b>	Part Number: <b>2691-42</b>	Drawn By: <b>Eng</b>	
Prepared Date: <b>4/17/20</b>	Revision Date: <b>Date</b>	Revision Number: <b>Rev #</b>	Sheet: <b>2 of 2</b>