



EDU AMATI AMICO DESK

SKU:2032-60

The Amati Amico Desk is a solid, durable and functional piece that will make a stunning first impression for your customers. Available in two finishes, the Amati Desk features full-depth drawers, a built-in laptop platform, cable management system and other integrated design elements that make this desk functional and stylish.

TECHNICAL INFORMATION

- Measures: 60"W x 26"D x 44"H
- Locking drawer w/ cash till
- Utility drawer
- Storage cabinets w/ adjustable shelves
- Recess for electronic cash drawer
- Can accommodate keyboard tray, specify at time of order
- Amati steel legs & accents
- Steel supported customer ledge
- Steel supported accent panel

SHIPPING INFORMATION

Item generally ships via Freight(Truck) service

- Weight: 340 lbs
- Dimensions: 66"L x 32"W x 50"H

WARRANTY

3 Years:

- Ball-Bearing Drawer Slides
- Cabinet hinges

1 Year:

- All remaining components, unless noted otherwise, are guaranteed for a period of one year from the date of purchase.



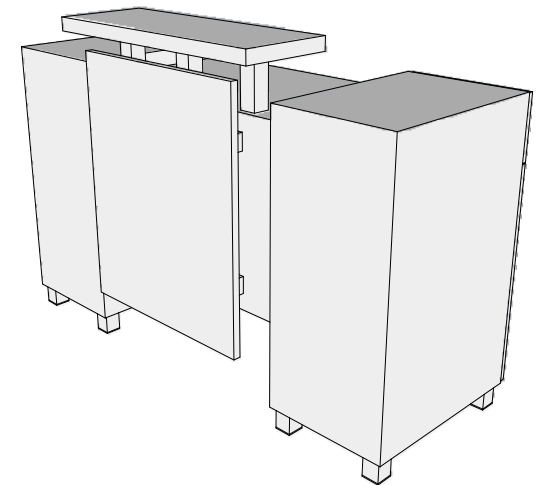
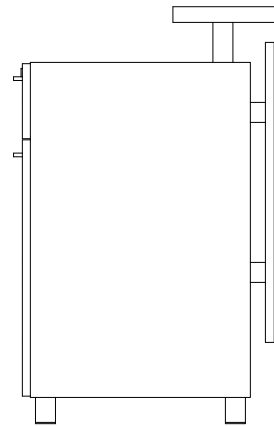
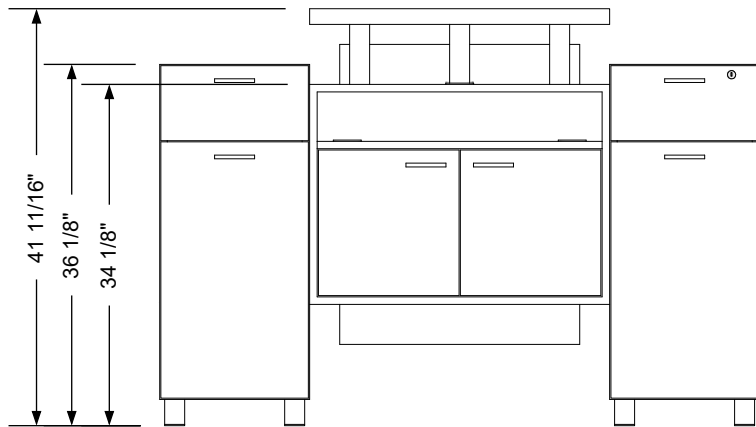
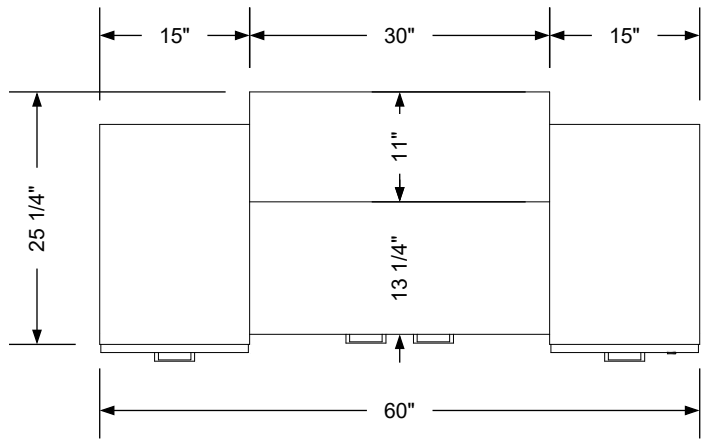

Additional Information

Assembly required - no
 Electrical required - yes
 Plumbing required - no
 Wall blocking required - no
 COM yardage/laminate usage - 89 sf
 2 1/2" h Metal leg + 1/8" h cap/glide
 Other (specify) - n/a
 Other (specify) - n/a

Specification Drawing

This **Specification Drawing** is intended for communicating the basic description, function, appearance, dimensions, features, and installation of an item as manufactured by Collins Manufacturing Company. Because this drawing does not contain project specific information such as quantities, finishes, or options, it is not an approval drawing and does not require a signature. This drawing remains the property of Collins Manufacturing Company and must not be used against the interests of Collins Manufacturing Company.

Product Information

		Collins Manufacturing 2000 Bowser Road Cookeville, TN 38506	
Name: Amati Amico Desk			
Size: NTS	Part Number: 2032-60	Drawn By: Eng	
Prepared Date: Date	Revision Date: Date	Revision Number: Rev #	Sheet: 1 of 2

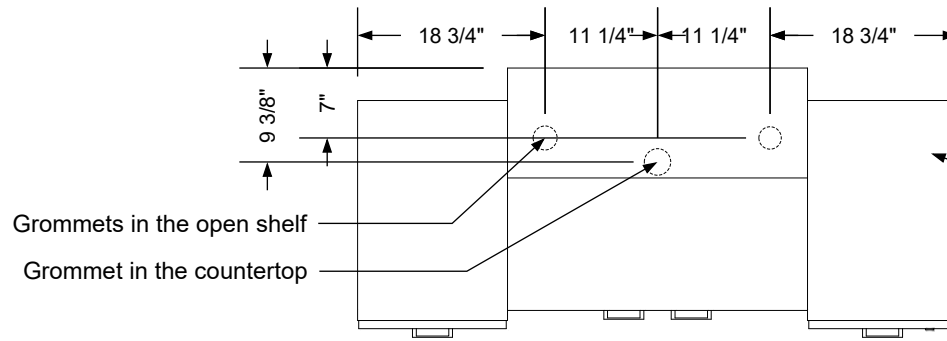

Provide 20 amp electrical power into the cabinets either through the bottom or end of one of the two cabinets. The power may then be directed through the desk and connected to outlets. The outlets are provided, installed, and wired by the electrician according to project-specific requirements.

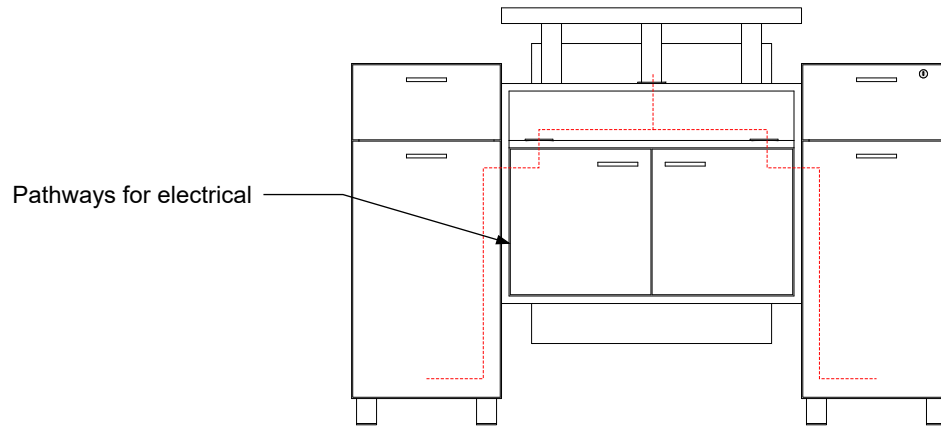

Electrical stub out detail

Additional Information

Assembly required - no
 Electrical required - yes
 Plumbing required - no
 Wall blocking required - no
 COM yardage/laminate usage - 89 sf
 2 1/2"h Metal leg + 1/8"h cap/glide
 Other (specify) - n/a
 Other (specify) - n/a

Specification Drawing

This **Specification Drawing** is intended for communicating the basic description, function, appearance, dimensions, features, and installation of an item as manufactured by Collins Manufacturing Company. Because this drawing does not contain project specific information such as quantities, finishes, or options, it is not an approval drawing and does not require a signature. This drawing remains the property of Collins Manufacturing Company and must not be used against the interests of Collins Manufacturing Company.

Product Information

		Collins Manufacturing 2000 Bowser Road Cookeville, TN 38506	
Name: Amati Amico Desk			
Size: NTS	Part Number: 2032-60	Drawn By: Eng	
Prepared Date: Date	Revision Date: Date	Revision Number: Rev #	Sheet: 2 of 2